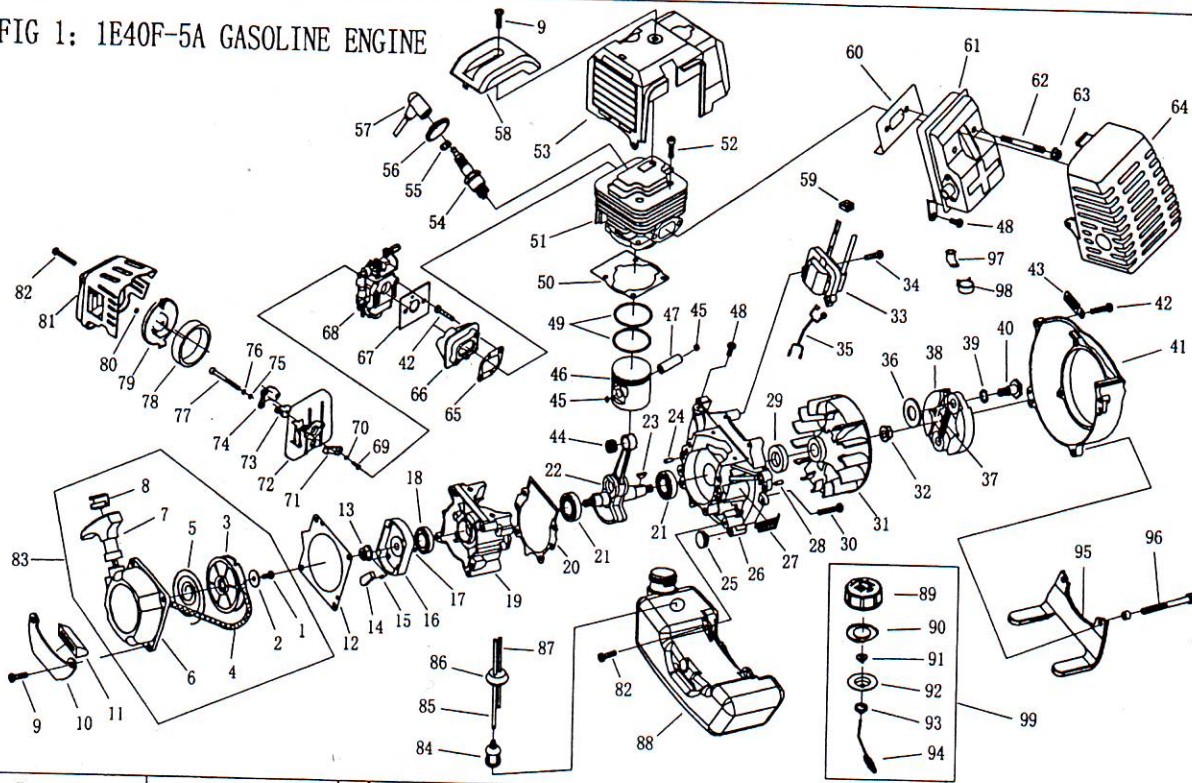
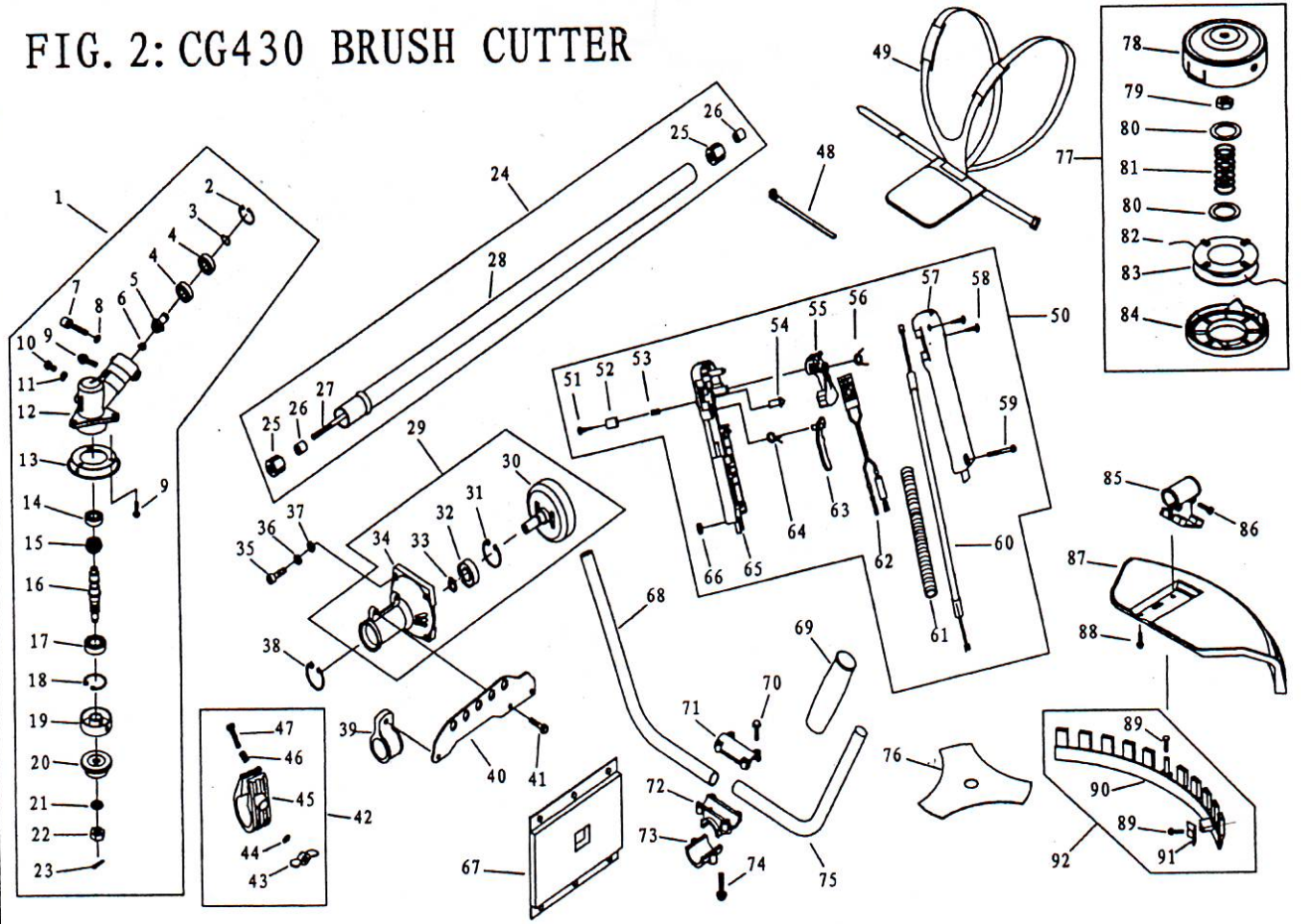

FIG 1: 1E40F-5A GASOLINE ENGINE



NO.	Part No.	Part Name	Qty.	NO.	Part No.	Part Name	Qty.	NO.	Part No.	Part Name	NO.
1	GB/T67	Screw M5×12-9.8	1	34	GB/T9074.13	Bolt M5×20	2	67	1E40F-5A-1	Gasket	1
2	1E40F-5.11-2	Washer	1	35	1E40F-5.3.1	Cord Comp.	1	68	WYK-171	Carburetor	1
3	1E40F-5.11-1	Start Rope Reel	1	36	1E36F-3	Washer B	2	69	GB/T845	Screw ST2.9×6.5	1
4		Rope	1	37	1E40F-5.6-1	Spring	1	70	GB/T97.1	Washer 3	1
5	1E40FP-3Z.4-7	Recoil Spring	1	38	1E40F-5.6.1	Expander	2	71	1E40F-5A.1.1-1	Choke Handle	1
6	1E40F-5.11.1	Start Cover Ass'y	1	39	1E40F-5-11	Washer	2	72	1E40F-5A.1.1.1	Inside Cover	1
7	1E40FP-3Z.4-2	Start Handle	1	40	1E40F-5-12	Screw Pin	2	73	1E40F-5A.1.1-2	Choke	1
8	1E40FP-3Z.4-10	Ring	1	41	1E40F-5-9	Fan Cover	1	74	1E40F-5A.1.2	Bufler	1
9	GB/T9074.4	Screw M5×20	5	42	GB/T9074.13	Bolt M5×25	4	75	GB/T97.1	Washer 5	2
10	1E40F-5A-4	Stand	1	43	1E40F-3A.9	Clip	1	76	GB/T93	Washer 5	2
11	1E40F-5A-2	Rubber Cover	1	44	1E40F-5.4-2	Bearing	1	77	GB/T70.1	Screw M5×55	2
12	1E40F-5-10	Gasket	1	45	1E40F-03.02.01	Ring	2	78	1E34F.1-1	Filter Net	1
13	GB/T6170	Nut M8	1	46	1E40F-5.4-1	Piston	1	79	1E40F-5A.1-2	Inside Cover	1
14	1E46FP.4-2	Start Claw	1	47	1E46FP.6-3	Piston Pin	1	80	GB/T3452.1	O-Washer 3.15×1.8	1
15	1E36F.1.2-2	Start Spring	1	48	GB/T9074.4	Bolt M5×12	3	81	1E40F-5A.1-1	Outside Cover	1
16	1E40F-5.7-1	Start Reel	1	49	1E40FP-3Z.3-5	Piston Ring	2	82	GB/T9074.4	Screw M5×16	3
17	GB/T896	Stop Ring 4	1	50	1E40F-5-6	Gasket	1	83	1E40F-5.11	Starter	1
18	1E36F.2	Seal	1	51	1E40F-5-4	Cylinder	1	84	1E34F.9.2-3	Cleaner Cover	1
19	1E40F-5.8-2	Crank Case	1	52	G3/T70	Screw M5×20	4	85	1E40F-5A.4.2-2	Fuel Pipe	1
20	1E40F-5.8-4	Gasket	1	53	1E40F-5.5	Guide Cover Ass'y	1	86	1E36FF.8.1-1	Plug	1
21	GB/T276	Bearing 6202/P4	2	54	L6 (LD)	Spark Plug	1	87	1E40F-5A.4.2-1	Fuel Pipe	1
22	1E40F-5.4.1	Crank Shaft	1	55		Spring	1	88	1E40F-5A.4.1	Fuel Tank	1
23	GB/T1099	Key 3×13	1	56		Plug Cap	1	89	1E32FL.6.2-1	Fuel Tank Lid	1
24	GB/T119	Pin B5×12	2	57		Cap	1	90	CG420.1.3.1-2	Gasket	1
25	1E40F-5A.4.2-1	Rubber Washer	2	58	1E40F-5-8	Cover	1	91	EB415.4.1.1-1	Inlet	1
26	1E40F-5.8-1	Crank Case	1	59	1E40F-5.3-1	Plug	1	92	1E32FL.6.2-2	Inside Cover	1
27	1E40F-5.8-3	Guide Cover	1	60	1E40F-5-5	Gasket	1	93	1E32FL.6.2-3	Inside Cover	1
28	GB/T119	Pin B4×10	2	61	1E40F-5.2	Muffler	1	94	1E32FL.6.2-4	Chain	1
29	1E40F-5.9	Seal	1	62	1E40F-5-13	Bolt	2	95	1E40F-5A.3	Stand	1
30	GB/T9074.4	Screw M5×30	4	63	GB/T6177	Nut M6	2	96	GB/T9074.13	Screw M5×30	2
31		Fly Wheel	1	64	1E40F-5-7	Muffler Cover	1	97	1E40F-5.10-1	Outlet	1
32	GB/T6177.1	Nut M8	1	65	1E40F-5-2	Admitting Pipe	1	98	1E40F-5.10-2	Stop Ring	1
33		Coil	1	66	1E40F-5A.2	Admitting Pipe	1	99	1E32FL.6.2	Fuel Tank Lid COMP.	1

FIG. 2: CG430 BRUSH CUTTER



NO.	PART NO.	PART NAME	QTY.	NO.	PART NO.	PART NAME	QTY.	NO.	PART NO.	PART NAME	QTY.
1	CG430-CE. 3	Gear Case Ass'y	1	32	GB/T276	Bearing 6202-2RS/P5	1	63	BL750. 3-3	Handgrip	1
2	GB/T893. 2	Stop Ring 26	1	33	GB/T894. 1	Stop Ring 15	1	64	BL750. 3-2	Spring	1
3	GB/T894. 1	Stop Ring 10	1	34	CG411. 1-1	Clutch Case	1	65	BL750. 3-6	Box, Left	1
4	GB/T276	Bearing 6000-2RS/P5	2	35	GB/T70. 1	Bolt M6 x 20	4	66	GB/T889. 1	Nut M5	1
5	CG415D. 6-4	Pinion	1	36	GB/T93	Washer 6	4	67	CG328. 3	Cushion	1
6	CG415. 3-1	Cap	1	37	GB/T848	Washer 6	4	68	CG411. 3-1	Handgrip	1
7	GB/T70. 1	Screw M6 x 20	1	38	GB/T893. 2	Stop Ring 37	1	69	CG330B-CE. 3-1	Rubber Cover	1
8	GB/T93	Washer 6	1	39	CG411-5	Hang Ring	1	70	GB/T9074. 13	Bolt M5 x 25	4
9	GB/T9074. 4	Screw M5 x 12	4	40	CG411-1	Hang Handle	1	71	CG415D-1	Cap, Uper	1
10	GB/T29. 2	Bolt M6 x 12	1	41	GB/T9074. 12	Bolt M6 x 16	3	72	CG415D-3	Bracket	1
11	GB/T97. 1	Washer 6	1	42	CG411. 2	Ring for Limit Ass'y	1	73	CG415D-2	Cap, Lower	1
12	CG415D. 6-2	Gear Case	1	43	GB/T62	Nut M6	1	74	GB/T9074. 13	Bolt M6 x 25	2
13	BG305. 12. 4-9	Cover	1	44	GB/T97. 1	Washer 6	1	75	CG415D. 2-2	Handle	1
14	GB/T276	Bearing 6000/P5	1	45	CG411. 2-1	Ring for Limit	1	76	CG420-2	Blade	1
15	BG-328. 9. 5-2	Gear	1	46	CG411. 2-2	Spring	1	77	CG305F. 8	Nylon Cutter Head	1
16	CG305F. 1-1	Gear Shaft	1	47	GB/T5781	Bolt M6 x 45	1	78	CG305F. 8. 1	Case	1
17	GB/T276	Bearing 6002-2RS/P5	1	48	BG415-1	Wire Clamp Band	2	79	CG305F. 8-4	Left Nut A	1
18	GB/T893. 2	Stop Ring 32	1	49	CG305F. 3A	Harness Ass'y	1	80	CG305F. 8-5	Washer	2
19	BG305. 12. 4-5	Holder A	1	50	CG430. 1. 1	Lever Ass'y	1	81	CG305F. 8-3	Spring	1
20	CG305F. 1-3	Holder B	1	51	GB/T846	Screw ST2. 9 x 13	1	82		Cord	1
21	GB/T862. 1	Washer 10	1	52	BL750. 3-9	Button	1	83	CG305F. 8-1	Cord Holder	1
22	CG305F. 1-4	Left Nut	1	53	BL750. 3-7	Spring	1	84	CG305F. 8-2	Cover	1
23	GB/T91	Pin 2 x 16	1	54	BL750. 3-8	Clock Pin	1	85	CG420. 7-1	Bracket	1
24	CG430-CE. 2	Pipe Comp.	1	55	BL750. 3-4	Handgrip	1	86	GB/T9074. 13	Screw M5 x 30	2
25	CG415D. 4-2	Rubber Cover	6	56	BL750. 3-1	Spring	1	87	CG420. 7. 1-1	Safety Guard	1
26	BG-328. 9. 4-4	Oil-Bearing	6	57	BL750. 3-5	Box, Right	1	88	GB/T9074. 4	Screw M5 x 16	4
27	CG420. 2-3	Drive Shaft	1	58	GB/T845	Screw ST2. 9 x 18	2	89	GB/T845	Screw ST4. 2 x 16	2
28	CG430-CE. 2. 1	Drive Shaft Pipe	1	59	GB/T70. 1	Screw M5 x 30	1	90	CG420. 7. 1. 1-1	Guard	1
29	CG411. 1	Clutch Comp.	1	60	CG430. 1. 1. 1	Cable Comp.	1	91	CG420. 7. 1. 1-2	Blade	1
30	CG415D. 1. 1	Clutch Drum Comp.	1	61	CG411. 3. 1. 1-1	Tube	1	92	CG420. 7. 1. 1	Guard Ass'y	1
31	GB/T893. 1	Stop Ring 35	1	62	CG430. 1. 1. 2	Stop Button Comp.	1				