

## 1E36F-2E GASOLINE ENGINE

NO.	Part No.	Part Name	Qty.	NO.	Part No.	Part Name	Qty.	NO.	Part No.	Part Name	Qty.	NO.	Part No.	Part Name	Qty.
1	1E36FE. 9-3	Screw	1	24	1E36F-2E. 2. 1. 1	MAGNETO ROTOR COMP.	1	47	L8RTC	Spark Plug	1	70	1E36F-E. 7-1	Cleaner Outside Cover	1
2	1E36FE. 9-4	Ratchet	1	25	GB/T859	Washer8	1	48	1E40F-3A. 8-2	Spring	1	71	1E34F. 1. 2	Screw	1
3	1E36FE. 9-1	Start Rope Reel	1	26	GB/T97. 1	Washer8	1	49	1E34F. 5-3	Plug Cap	1	72	CG330-E-1	Stand	1
4	1E36FE. 9-5	Rope	1	27	GB6170	Nut M8	1	50	1E34F. 5-2	Cap	1	73	1E40F-5A-2	Rubber Cover	1
5	1E36FE. 9-7	Recoil Spring	1	28	1E36F-2E. 2. 1. 2	IGNITION COIL COMP.	1	51	1E40F-5. 3-1	Plug	1	74	P40. 12. 2-3A	Cleaner Cover	1
6	1E36FE. 9-8	Start Cover Ass'y	1	29	1E36F-2. 3. 1	Cord Comp.	1	52	1E36F-E-4	Cover	1	75	CG420. 1. 3. 2-2	Fuel Pipe 3×1×145	1
7	GB70. 1+GB93+GB97	Screw M5 × 20	6	30	GB70. 1+GB93+GB97	Screw M5 × 20	6	53	1E36F-E-2	Gasket	1	76	EB-415. 4. 2-2	Plug	1
8	1E40FP-3Z. 4-2	Start Handle	1	31	1E36F-3	WasherB	2	54	HA36-2. 3	Muffler	1	77	EB-415. 4. 2-4	Fuel Pipe 2.5×1.25×90	1
9	1E40FP-3Z. 4-10	Ring	1	32	1E36F-E. 6B-1	Spring	1	55	GB70. 1+GB93+GB97	Screw M5 × 12	1	78	GB70. 1+GB93+GB96	Screw M5 × 16	2
10	1E36FE. 9-6	Spring	1	33	1E36F-2C. 4. 1	Expander	2	56	1E33F-4	Gasket	2	79	1E36FE. 10-1	Fuel Tank	1
11	1E36FE. 9-2	Start pole	2	34	1E40F-5-11	Washer	2	57	GB70. 1+GB97	Screw M5 × 60-12. 9	2	80	1E32FL. 6. 2-4	Chain	1
12	1E36FE. 9	Starter	1	35	P40-18	Screw Pin	2	58	1E36F-E-8	Gasket	1	81	1E32FL. 6. 2-3	End Cover	1
13	1E40F-5-10	Gasket	1	36	1E36FE-5	Fan Cover	1	59	1E36F-2A-2	Admitting Pipe	1	82	1E32FL. 6. 2-2	Inside Cover	1
14	1E36FE. 7	Start Reel	1	37	1E36F-2. 4. 1	Bearing	1	60	1E34F-1	Gasket	1	83	EB-415. 4. 1. 1-1	Inlet	1
15	1E36F. 2	Oil-seal	2	38	1E36F. 10-2	Ring	2	61	1E34F-2E. 1A	Carburetor	1	84	CG420. 1. 3. 1-2	Gasket	1
16	1E36F-E. 8-2	Crank Case	1	39	1E36F-E. 4-1	Piston	1	62	1E34F. 1-2	Choker Handle	1	85	1E32FL. 6. 2-1	Fuel Tank Lid	1
17	1E36F-2. 6-3	Gasket	1	40	1E36F. 10-1	Piston Pin	1	63	1E34F. 1-7	Stop ring	1	86	1E32FL. 6. 2	Lid Ass'y	1
18	GB/T276	Bearing 6201/P6	2	41	1E36F. 10-3	Piston Ring	2	64	GB/T6170	Nut M4	1	87	1E40F-5A-3	Rubber washer	2
19	1E36F-E. 4. 1	Crank Shaft	1	42	1E36F-E-3	Gasket	1	65	1E34F. 1. 1	Cleaner inside cover	1	88	1E36F-2E-3	Cover	1
20	GB/T1099	Key 3 × 5 × 13	1	43	1E36F-2E-1	Cylinder	1	66	GB70. 1+GB97	Screw M5 × 55	2	89	GB70. 1+GB93+GB97	Screw M4 × 12	1
21	GB/T119. 1	Pin 4h8 × 10	4	44	GB/T70. 1	Screw M5 × 18	4	67	1E34F. 1-3	CHOKER	1	90			
22	1E36F-E. 8-1	Crank Case	1	45	1E36F-E. 5	Guide Cover Ass'y	1	68	GB/T845	Screw ST4. 2 × 12	1				
23	GB/T70. 1	Screw M5 × 30	4	46	GB70. 1+GB93+GB97	Screw M5 × 16	1	69	1E34F. 1-1	Filter Net	1				

# BRUSHCUTTER MACHINE SPARE PARTS LIST GJD330

1/4

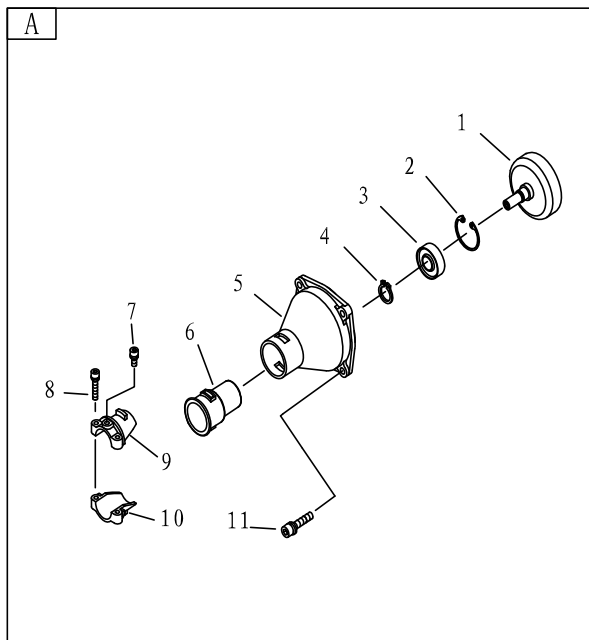

NO.	PART NO.	PART NAME	QTY.
A	CG415.2	Clutch Comp.	
1	CG415D.1.1A	Clutch Drum Comp.	1
2	GB/T893.1	Stop Ring 35	1
3	GB/T276	Bearing 6202-2RZ/P6	1
4	GB/T894.1	Stop Ring 15	1
5	CG305F.14-1	Linker	1
6	CG305F.14-2	Rubber Cover	1
7	GB70+GB93+GB97	Screw M5×12	1
8	GB70+GB93+GB97	Screw M5×25	2
9	CG305F.14-4	Clamp A	1
10	CG305F.14-3	Clamp B	1
11	GB70+GB93+GB97	Screw M6×20	4

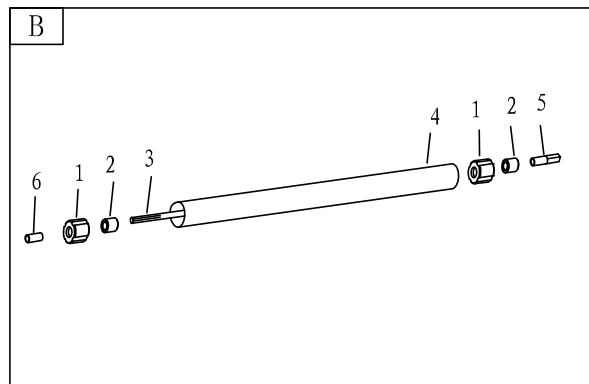

NO.	PART NO.	PART NAME	QTY.
B	CG260BF.1.1	Rear-Pipe Comp.	1
1	BG-328.9.4-5	Rubber Cover	3
2	BG-328.9.4-4	Oil-bearing	3
3	CG260BF.1.1-1	Drive Shaft	1
4	CG260BF.1.1-2	Pipe	1
5	CG260BF.1.1-3	Joining Shaft	1
6	BG415-6(∅10×∅6×2)	Rubber Pipe (5mm)	1

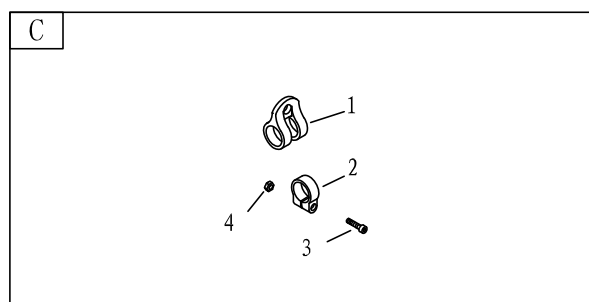

NO.	PART NO.	PART NAME	QTY.
C	CG260.3	Holder Ass'y	
1	CG260.3.1	Harness Clamp	1
2	CG260.3-1	Clamp	1
3	GB/T70.1	Screw M5×20	1
4	GB/T889.1	Nut M5	1

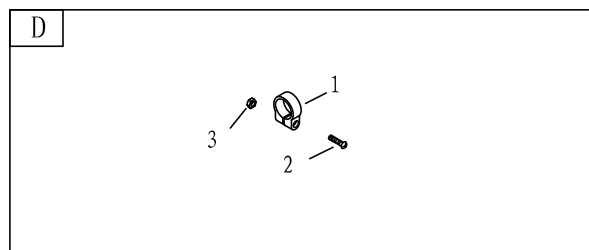

NO.	PART NO.	PART NAME	QTY.
D		Clamp Ass'y	2
1	CG260.3-1	Clamp	1
2	CG260.3-2-2012CE	Screw M5×18	1
3	GB/T889.1	Nut M5	1

# BRUSHCUTTER MACHINE SPARE PARTS LIST GJD330

2/4

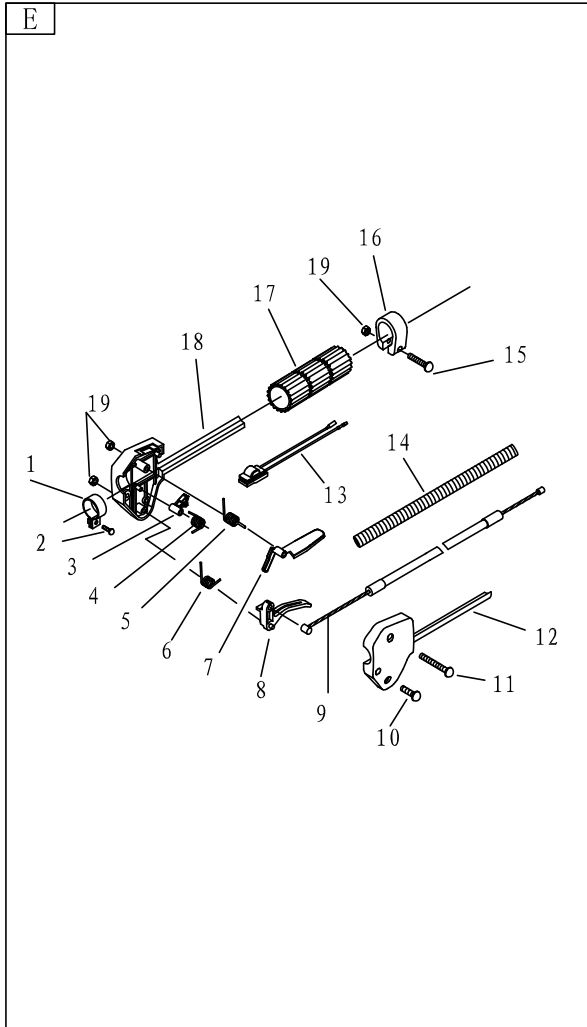

NO.	PART NO.	PART NAME	QTY.
E		Level Ass'y	1
1	CG305F. 13. 2	Clamp	1
2	GB/T9074. 4	Screw M5×16	1
3	CG305F. 13-10	Tine	1
4	CG305F. 13-11	Spring	1
5	CG305F. 13-9	Spring	1
6	CG305F. 13-1	Spring	1
7	CG305F. 13-8	Safety Lever	1
8	CG305F. 13-2	Throttle Lever	1
9	CG260. 2. 2C	Cable Comp.	1
10	GB/T9074. 4	Screw M5×25	2
11	GB/T9074. 5	Screw M5×30	1
12	CG305F. 13-3	Box, Left	1
13	CG260. 2. 1	Stop Switch	1
14	BG-328A-2	Tube	0.17m
15	GB/T9074. 4	Screw M5×25	1
16	CG305F. 13-5	Clamp	1
17	CG305F. 13-6	Rubber Cover	1
18	CG305F. 13-4	Box, Right	1
19	GB/T889. 1	Nut M5	3

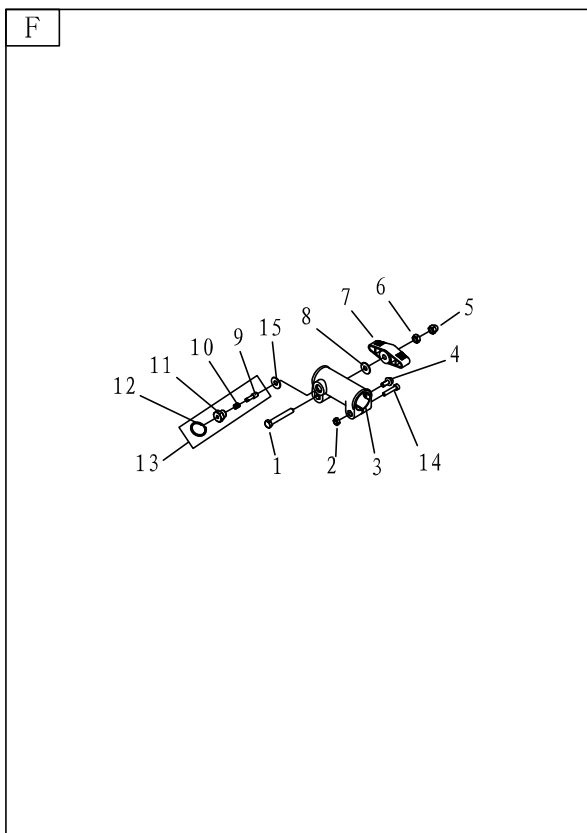

NO.	PART NO.	PART NAME	QTY.
F	CG260BF. 1. 2	Joining Ass'y	1
1	GB/T5781	Bolt M6×55	1
2	GB/T889. 1	Nut M5	1
3	CG260BF. 1. 2-2	Joining	1
4	GB/T5789	Bolt M5×12	1
5	GB/T923	Nut M6	1
6	GB/T6170	Screw M6	1
7	CG260BF. 1. 2-1	Handle	1
8	GB/T96	Washer 6	1
9	BG305. 2. 1-1	Bin	1
10	BG305. 2. 1-2	Spring	1
11	BG305. 2. 1-3	Cover	1
12	BG305. 2. 1-4	Loop	1
13	BG305. 2. 1	Bin comp.	1
14	GB/T70. 1	Screw M5×25	1
15	1E46FP-15	Washer	1

# BRUSHCUTTER MACHINE SPARE PARTS LIST GJD330

3/4

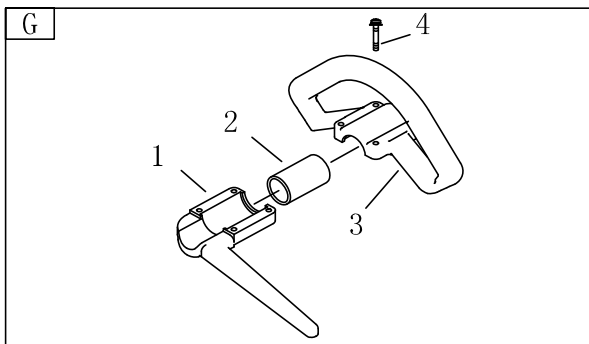

NO.	PART NO.	PART NAME	QTY.
G	CG245Q. 11	Handle Comp.	
1	CG245Q. 11. 1	Handle Cover	1
2	BG330-CE. 1-2-2012CE	Rubber Cover	1
3	CG245Q. 11-1	Handle	1
4	BC36. 4-2+GB93+GB97	Screw M5×35	4

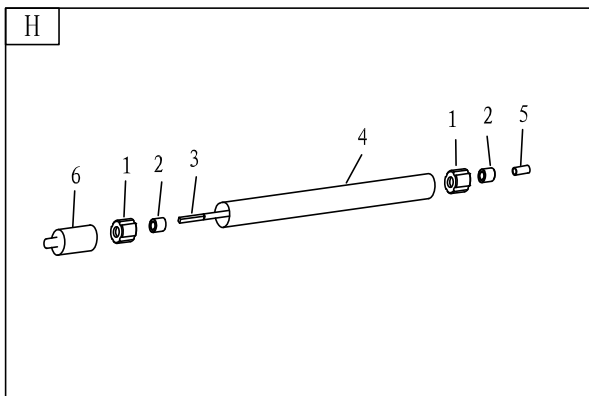

NO.	PART NO.	PART NAME	QTY.
H	CG260BF. 1. 3. 1	Fore-Pipe Comp.	1
1	BG-328. 9. 4-5	Rubber Cover	3
2	BG-328. 9. 4-4	Oil-bearing	3
3	CG260BF. 1. 3. 1-1	Drive Shaft	1
4	CG260BF. 1. 3. 1-2	Pipe	1
5	∅10×∅6×2	Rubber Pipe (5mm)	1
6	BG305. 1-1	Rubber Cover	1

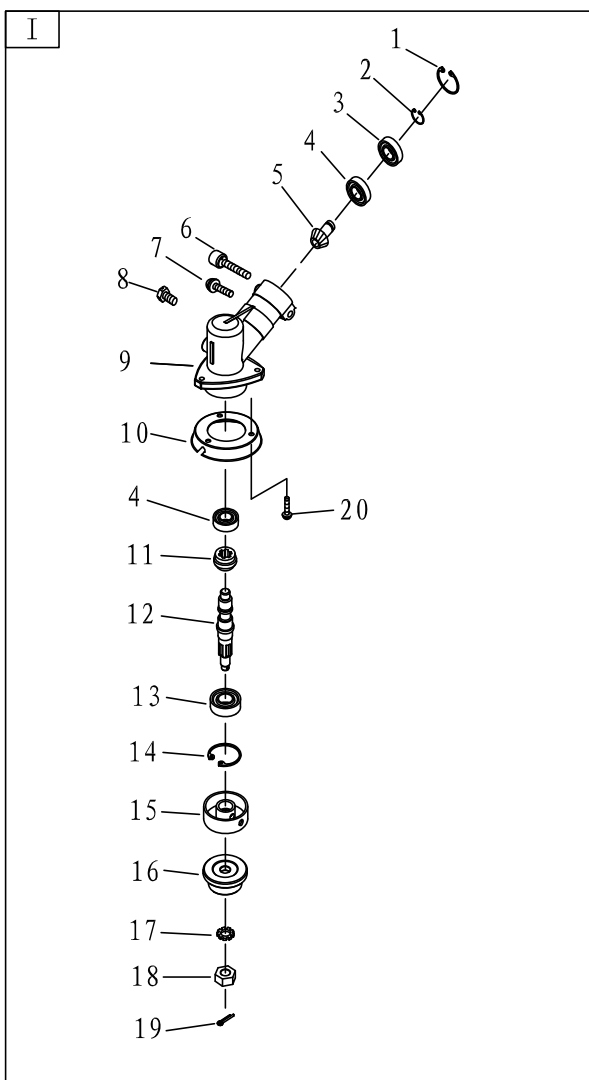

NO.	PART NO.	PART NAME	QTY.
I	CG415. 3	Gear Case Ass'y	
1	GB/T893. 2	Stop Ring 26	1
2	GB/T894. 1	Stop Ring 10	1
3	GB/T276	Bearing 6000-2RS/P6	1
4	GB/T276	Bearing 6000/P6	2
5	CG415D. 6-4	Pinion	1
6	GB/T70. 1+GB93	Screw M5×20	1
7	GB70+GB93+GB97	Screw M5×12	1
8	GB/T9074. 11	Bolt M5×12	1
9	BG305. 12. 4-4	Gear Case	1
10	BG330H. 7. 3-1	Safety Guard	1
11	BG-328. 9. 5-2	Gear	1
12	CG305F. 1-1	Gear Shaft	1
13	GB/T276	Bearing 6002-2RS/P6	1
14	GB/T893. 2	Stop Ring 32	1
15	BG305. 12. 4-5	Holder A	1
16	CG305F. 1-3	Holder B	1
17	GB/T862. 1	Washer 10	1
18	CG305F. 1-4	Left Nut	1
19	GB/T91	Pin 2×16	1
20	GB/T9074. 4	Screw M5×12	3

# BRUSHCUTTER MACHINE SPARE PARTS LIST GJD330

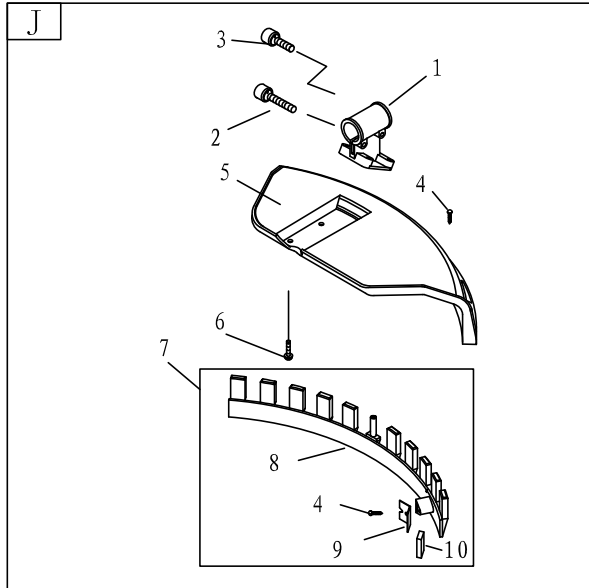

NO.	PART NO.	PART NAME	QTY.
J	BG430. 2. 6	Guard Ass'y	
1	BG430-JCB. 1	Bracket	1
2	GB70+GB93+GB97	Screw M5×30	2
3	GB70	Screw M5×12	1
4	GB/T845	Screw ST4. 2×16	3
5	CG420. 7. 1-1	Safety Guard	1
6	1E40F-5A-CE-4	Screw M5×16	4
7	CG420. 7. 1. 1	Guard Ass'y	1
8	CG420. 7. 1. 1-1	Guard	1
9	CG420. 7. 1. 1-2A	Blade	1
10	CG420-5	Blade Cover	2

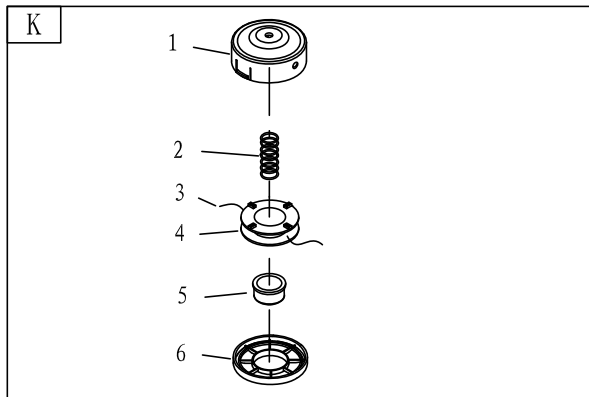

NO.	PART NO.	PART NAME	QTY.
K	CG520-HS. 1	Nylon Cutter Head	
1	CG520-HS. 1. 1	Case	1
2	CG520-HL. 17-3	Spring	1
3		Cord $\phi$ 2. 5×2100	2
4	CG520-HL. 17-2	Cord Holder	1
5	CG520-HL. 17-4	Cover	1
6	CG520-HL. 17-1	Cover	1

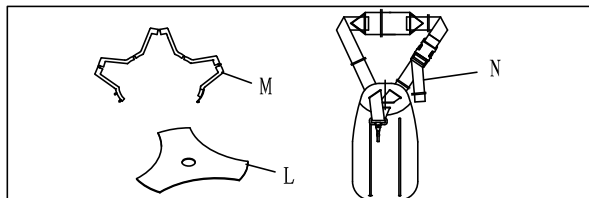

NO.	PART NO.	PART NAME	QTY.
L	CG420-2	Blade	1
M	CG420-3	Guard	1
N	CG260A-CE. 1	Harness Ass'y	1



The hedgetrimmer head parts list of GJD330

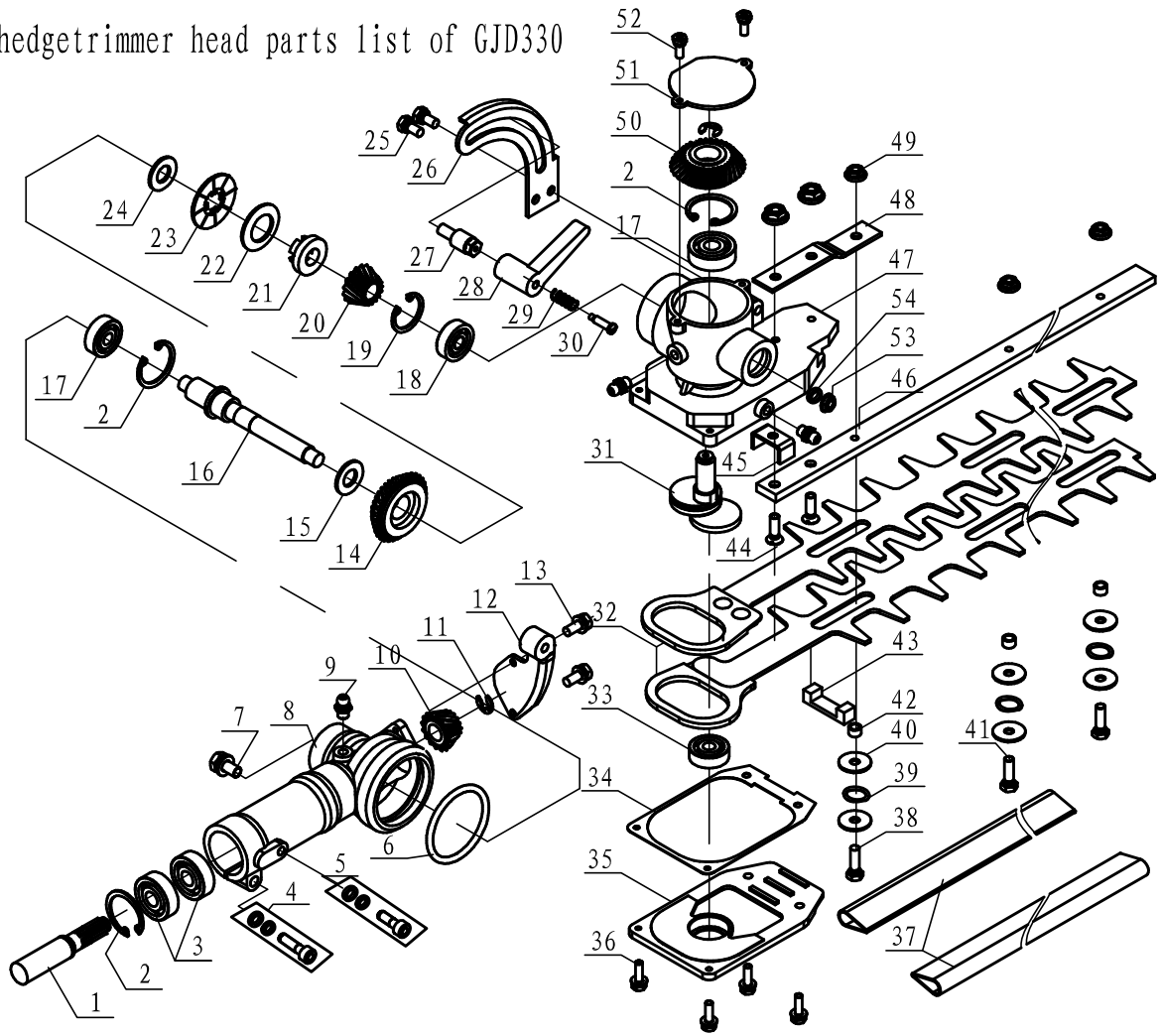

NO.	PART NO.	DESCRIPTION	QTY.	NO.	PART NO.	DESCRIPTION	QTY.	NO.	PART NO.	DESCRIPTION	QTY.
1	GJ330.2.1	GEAR SHAFT	1	19	GB/T893.1	STOP RING 22	1	37	GJ330.2-3	BLADE COVER	1
2	GB/T893.1	STOP RING 26	3	20	GJ330.2.2-2	PINION	1	38	GB/T29.2	SCREW M5×20	1
3	GB/T276	BEARING 6000-RS/P5	2	21	GJ330.2.2-3	LIMIT LOCATION BLOCK	1	39	1E34F-13	WASHER	4
4	GB70+GB93+GB97	SCREW M5×25	1	22	GJ330.2.2-4	DISHING WASHER	1	40	GJ330.2-6	WASHER 5	8
5	GB70+GB93+GB97	SCREW M5×14	1	23	GJ330.2.2-5	LOCATION PAD	1	41	GB/T29.2	SCREW M5×18	3
6	GJ330.2-4	"O" CIRCLE 40.2	1	24	GJ330.2.2-8	RUBBER COVER 10	1	42	GJ330.2-8	GASKET	4
7	GB/T9074.13	BOLT M6×16	1	25	GB/T9074.12	BOLT M5×10	2	43	GJ330.2-10	SEALGASKET	1
8	GJ330.2-1	GEAR CASE ASSY	1	26	GJ330.2-15	LOCATION BOARD	1	44	GB/T819	SCREW M5×18	2
9	GB/T 1152	OIL CUP M6	3	27	GJ330.2.4-3	SCREW M6	1	45	GJ330.2-16	LIMIT LOCATION BLOCK	1
10	GJ330.2-2	LEFT PINION	1	28	GJ330.2.4-1	HANDLE	1	46	GJ330.2-7	BLADE BRACKET	1
11	GB/T896	STOP RING 6	2	29	GJ330.2.4-2	SPRING	1	47	GJ330.2-5	DRIVE CASE	1
12	GJ330.2.5	ORIENTATION STAND	1	30	GJ330.2.4-4	SCREW M3×12	1	48	GJ330.2-9	GASKET	1
13	GB/T9074.12	BOLT M4×10	2	31	GJ330.2-12	CAM SHAFT	1	49	GB/T 6187	NUT M5	6
14	GJ330.2.2-7	GEAR	1	32	GJ330.2.3	BLADE RIVETING	1	50	GJ330.2-13	RIGHT PINION	1
15	GJ330.2.2-6	RUBBER COVER 14	1	33	GB/T276	BEARING 608-RS/P5	1	51	GJ330.2-14	DRIVE CAST CAP	1
16	GJ330.2.2-1	SPINDLE	1	34	GJ330.2-17	SEAL GASKET	1	52	GB/T9074.12	BOLT M4×10	2
17	GB/T276	BEARING6000-2RS/P5	2	35	GJ330.2-11	DRIVE CASE CAP	1	53	GB/T 889	NUT M6	1
18	GB/T276	BEARING 608-2RS/P5	1	36	GB9074.13	SCREW M4×14	4	54	GB/T 97	WASHER 6	1