

This catalog covers:
TH023V-□C50

This fig. covers:
TITLE

PARTS CATALOG

2-STROKE ENGINE

TH023V

PRODUCT CODE	NOTE
TH023V-AC50	BRUSH-CUTTER (TM3200)
TH023V-BC50	

This catalog covers:
TH023V-□C50

PARTS CATALOG INTRODUCTION

This parts catalog lists parts and sub-assemblies provided as service parts.

When it becomes necessary to replace parts, always use KAWASAKI GENUINE PARTS which have passed strict inspection which guarantees quality and performance.

1. HOW TO ORDER PARTS

- When ordering the parts, be sure to use the parts catalog corresponding to the product code. Check the product revision codes on the product and the catalog.
 Product Code (example) : FA130D-AA00
 Product Revision Code
- Specify the part code (all digits) exactly as listed in this catalog on your parts order.
- The parts not shown in the illustrations of this catalog are not sold separately; only the complete units or next higher assemblies illustrated are supplied as the service parts.

2. EXPLANATION OF PARTS CATALOG FORMAT

This catalog covers: **TH026D-□A10**

This fig. covers: **01 CYLINDER/CRANKCASE**

Ref. No.	Part No.	Description	Quantity
11005	11005-2137	CYLINDER-ENGINE	1
11060	11060-2402	GASKET,CYLINDER	1
11065	11065-2064	CAP	2
14002	14002-2327	CRANKCASE	1
14002A	14002-2328	CRANKCASE	1
34001	34001-2083	STAND	1
92009	92009-2115	SCREW	3
92045	92045-1502	PIN	2
92045	92045-2006	BEARING-BALL,6000C3	2
92049	92049-2074	SEAL-OIL	2
92150	92150-2091	BOLT	4

1 JUN.03.1999 E0110-A216A

1) Product Code

This code describes the product code covered by this catalog. The product revision code, which is a part of the product code, is omitted.

2) Part Group Title

This title is the representative name for the group of parts illustrated on the page.

3) Reference Number

The reference numbers are shown on the illustration and the list as the link between them.

This fig. covers:
PARTS LIST INFORMATION

4) Part Number

This is the key of your parts ordering.

Three kinds of part number are used in this catalog.

a. Structure 1

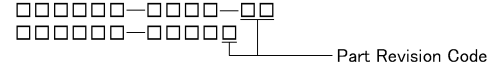

b. Structure 2

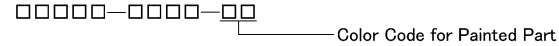

c. Standard Hardware Number

(for bolts, nuts, washer, or the like)

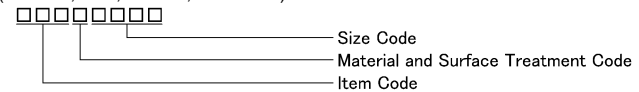

5) Description and Additional Information

The part name, the location, the size, and the serial number as additional information, etc. are described here. Use them to find out and check the part required.

When a part number is changed without change of the product revision code and the changed parts are not interchangeable, the serial number of the product is noted as follows;

- (FA130 - 100001) : Affected units are from beginning of the product of the product code up to and including this serial number.
- (FA130 - 100002 -) : Affected units are from this serial number and above.
- (FA130 - 100002 - FA130 - 110001) : Affected units are in this serial number range.

6) Quantity

The figure shows quantity of the part required at the indicated position on the illustration and for the specified product revision code.

The asterisk (*) on this column means the part can be used as the substitute on the product and is supplied until the stock is exhausted.

Note:Some small parts will be supplied by units.

Example: If six (6) bolts are ordered and the minimum quantity per unit is five (5), two (2), units of the bolt will be delivered.

7) Product Revision Code

This Code indicates an important change which affects the service parts interchangeability.

3. ABBREVIATIONS

#.....Number	FR.....Front	RH.....Right Hand
&.....And	G.....Gram	RPM.....Revolutions Per Minute
(+).....Plus	HEX.....Hexagonal	RR.....Rear
(-).....Minus	ID=.....Inside Diameter	STD.....Standard
2ND.....Second	IN.....Inch	T.....Teeth
3RD.....Third	L=.....Length	T=.....Thickness
4TH.....Fourth	LH.....Left Hand	U/S.....Under Size
A.....Ampere	LWR.....Lower	UPP.....Upper
AR.....As Required	MM.....Millimeter	V.....Volt
ASSY.....Assembly	O/S.....Over Size	W.....Watt
CNT.....Center	OD=.....Outside Diameter	
COMP.....Complete	REF.....Reference	

This catalog covers:

TH023V- □ C50

This fig. covers:

01 CYLINDER/CRANKCASE

E0110-A391A

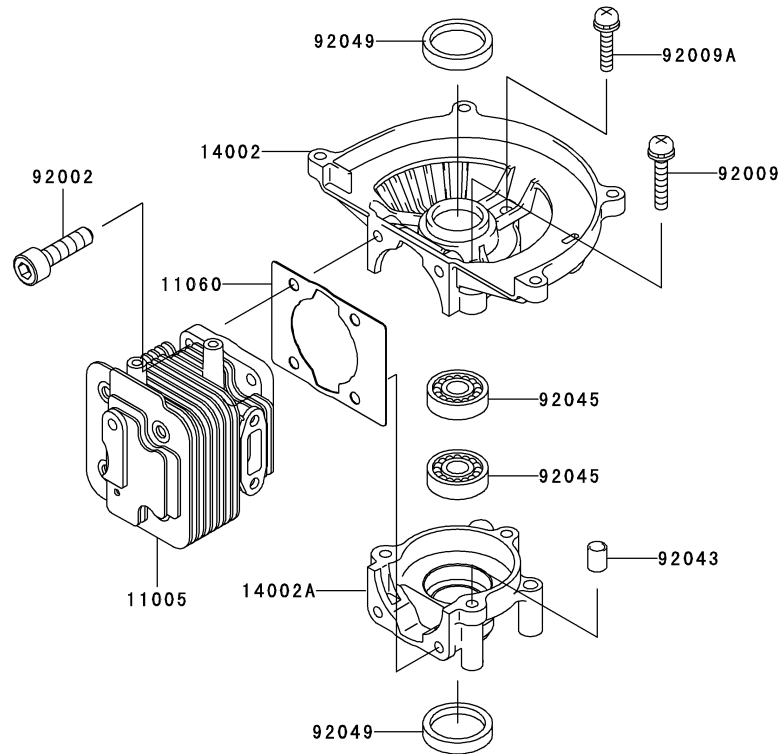

Ref. No.	Part No.	Description	Quantity	
			A	B
11005	11005-2150	CYLINDER-ENGINE	1	1
11060	11060-2402	GASKET,CYLINDER	1	1
14002	14002-2349	CRANKCASE	1	1
14002A	14002-2350	CRANKCASE	1	1
92002	92002-2163	BOLT	4	4
92009	92009-2115	SCREW	2	2
92009A	92009-2235	SCREW,5X25	1	1
92043	92043-1302	PIN	2	2
92045	92045-2060	BEARING-BALL,6001V3	2	2
92049	92049-2108	SEAL-OIL	2	2

This catalog covers:

TH023V- □ C50

02

This fig. covers:

PISTON/CRANKSHAFT

E0120-A204F

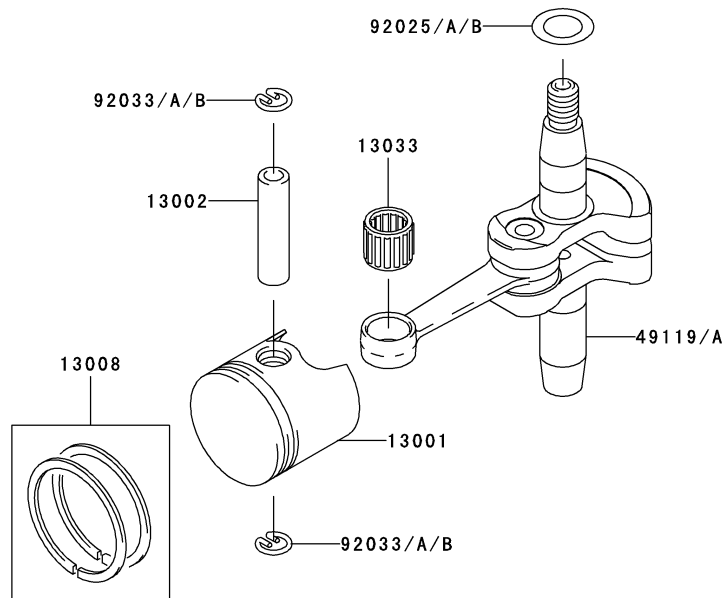

Ref. No.	Part No.	Description	Quantity	
			A	B
13001	13001-2154	PISTON-ENGINE	1	1
13002	13002-2058	PIN-PISTON	1	1
13008	13008-6050	RING-SET-PISTON	1	1
13033	13033-2055	BEARING-SMALL END	1	1
49119	49119-2205	CRANKSHAFT-ASSY	1	
49119A	49119-2237	CRANKSHAFT-ASSY		1
92025	92025-2104	SHIM,T=0.20	AR	AR
92025A	92025-2105	SHIM,T=0.40	AR	AR
92025B	92025-2106	SHIM,T=0.60	AR	AR
92033	92033-2060	RING-SNAP	*	
92033A	92033-2191	RING-SNAP		2
92033B	92033-2191	RING-SNAP	2	

This catalog covers:

TH023V- □ C50

This fig. covers:

03 COOLING-EQUIPMENT

E0150-A459G

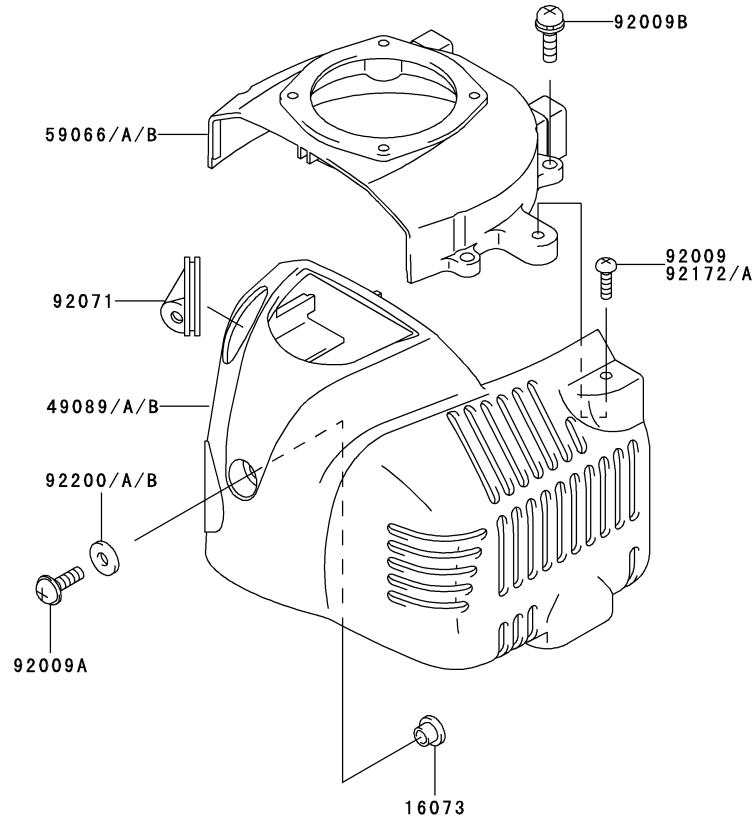

Ref. No.	Part No.	Description	Quantity	
			A	B
16073	16073-2197	INSULATOR	1	1
49089	49089-2552	SHROUD-ENGINE	*	
49089A	49089-2585	SHROUD-ENGINE		1
49089B	49089-2585	SHROUD-ENGINE	1	
59066	59066-2763	HOUSING-FAN	*	
59066A	59066-2781	HOUSING-FAN		1
59066B	59066-2781	HOUSING-FAN	1	
92009	92009-2236	SCREW,4X14	*	
92009A	92009-2394	SCREW,5X16	1	1
92009B	92009-2395	SCREW,5X16	4	4
92071	92071-2160	GROMMET	1	1
92172	92172-2061	SCREW,4X14		1
92172A	92172-2061	SCREW,4X14	1	
92200	92200-2063	WASHER,5.5X13.8X2.0	*	
92200A	92200-2156	WASHER		1
92200B	92200-2156	WASHER	1	

This catalog covers:

TH023V- □ C50

04

This fig. covers:

ELECTRIC-EQUIPMENT

E0160-A797B

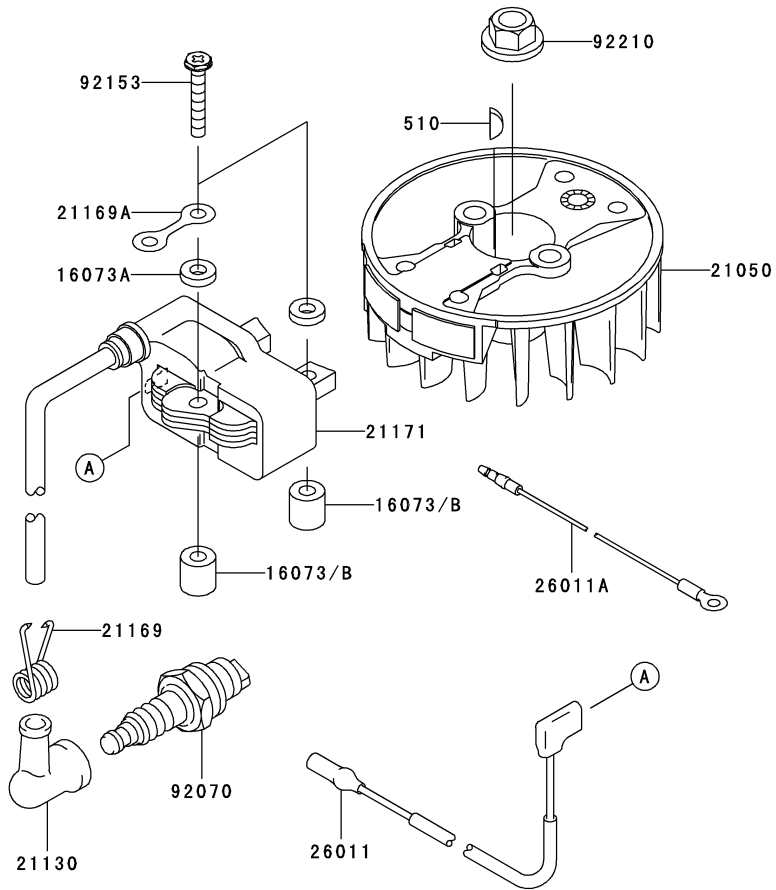

Ref. No.	Part No.	Description	Quantity	
			A	B
16073	16073-2214	INSULATOR	2	
16073A	16073-2215	INSULATOR	2	2
16073B	16073-2220	INSULATOR		2
21050	21050-2296	FLYWHEEL	1	1
21130	21130-2056	CAP-SPARK PLUG	1	1
21169	21169-2051	TERMINAL	1	1
21169A	21169-2072	TERMINAL	1	1
21171	21171-2241	COIL-ASSY-IGNITION	1	1
26011	26011-2372	WIRE-LEAD,X260	1	1
26011A	26011-2373	WIRE-LEAD,X130	1	1
92070	92070-2108	PLUG-SPARK,BPMR6A(NGK),SOLID	1	1
92153	92153-2069	BOLT,04X25	2	2
92210	92210-2094	NUT	1	1
510	510A3100	KEY-WOODRUFF	1	1

This catalog covers:

TH023V- □ C50

05

This fig. covers:

CARBURETOR

E0180-A712B

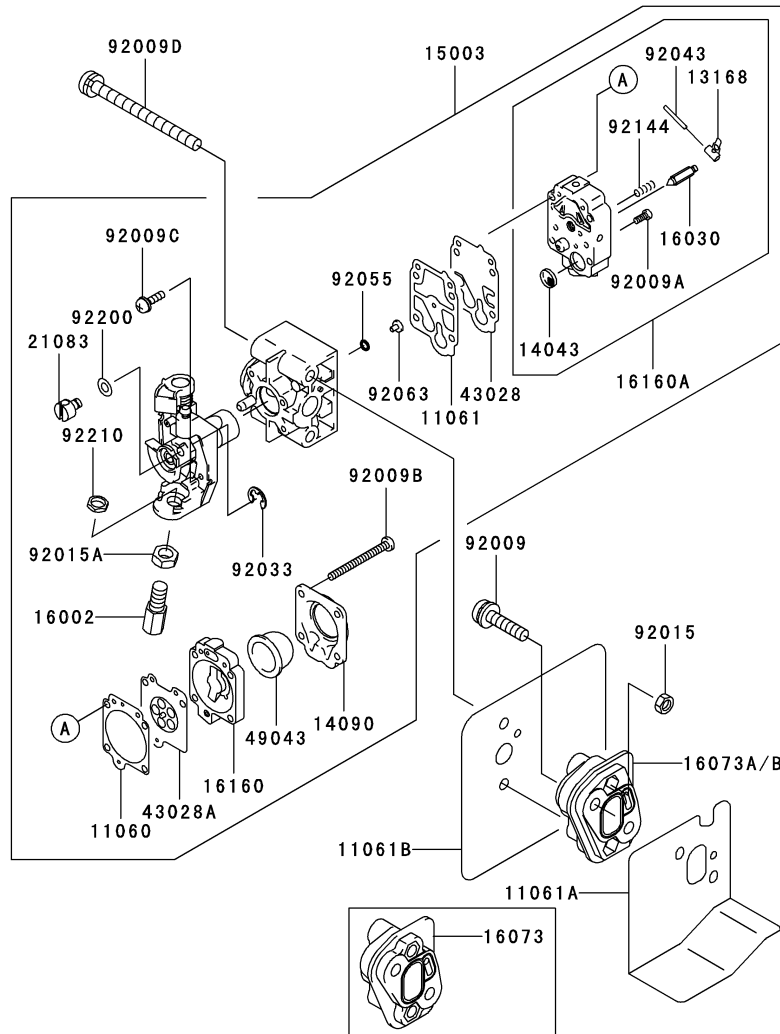

Ref. No.	Part No.	Description	Quantity	
			A	B
11060	11060-2111	GASKET	1	1
11061	11061-2054	GASKET	1	1
11061A	11061-2098	GASKET	1	1
11061B	11061-2107	GASKET,CARBURETOR	1	1
13168	16055-2051	LEVER	1	1
14043	14043-2051	FILTER	1	1
14090	14090-2017	COVER,PRIMER PUMP	1	1
15003	15003-2807	CARBURETOR-ASSY	1	1
16002	16002-2058	ADJUSTER-CABLE	1	1
16030	16030-2078	VALVE-FLOAT	1	1
16073	16073-2190	INSULATOR	*	
16073A	16073-2231	INSULATOR		1
16073B	16073-2231	INSULATOR	1	
16160	16160-2089	BODY	1	1
16160A	16160-2103	BODY	1	1
21083	21083-2073	ARM	1	1
43028	43028-2067	DIAPHRAGM	1	1
43028A	43028-2090	DIAPHRAGM	1	1
49043	49043-2067	PUMP-PRIMING	1	1
92009	92009-2249	SCREW,5X20	2	2
92009A	92009-2336	SCREW	1	1
92009B	92009-2337	SCREW	4	4
92009C	92009-2373	SCREW	2	2
92009D	92009-2398	SCREW,5X60	2	2
92015	92015-2097	NUT,M5	2	2
92015A	92015-2145	NUT	1	1
92033	92033-2078	RING-SNAP	1	1
92043	92043-2094	PIN	1	1
92055	92055-2147	RING-O	1	1
92063	92063-2425	JET-MAIN,#32.5	1	1
92144	92144-2308	SPRING	1	1
92200	92200-2074	WASHER	1	1
92210	92210-2089	NUT	1	1

This catalog covers:

TH023V- □ C50

06

This fig. covers:

AIR-FILTER/MUFFLER

E0190-A730C

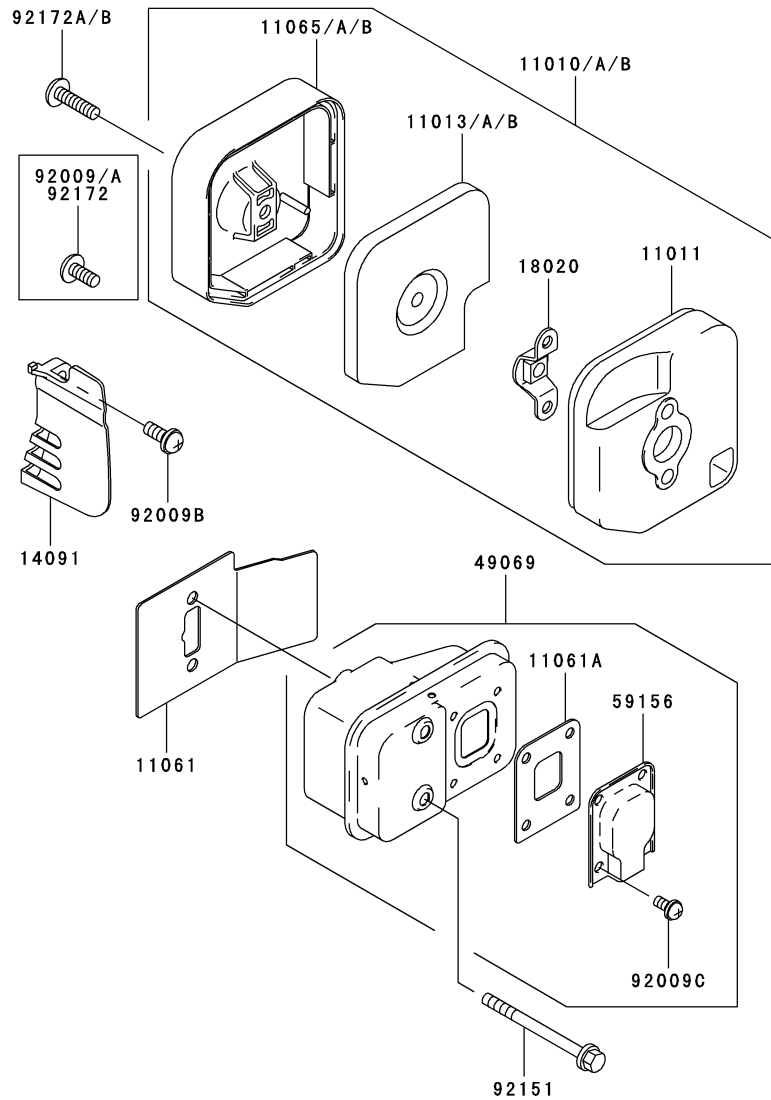

Ref. No.	Part No.	Description	Quantity	
			A	B
11010	11010-2553	FILTER-ASSY-AIR	1	
	(-		
	TH023-167459)			
11010A	11010-2572	FILTER-ASSY-AIR		1
11010B	11010-2572	FILTER-ASSY-AIR	1	
	(TH023-167460 -		
)			
11011	11011-2332	CASE-AIR FILTER	1	1
11013	11013-2193	ELEMENT-AIR FILTER	*	
11013A	11013-2208	ELEMENT-AIR FILTER		1
11013B	11013-2208	ELEMENT-AIR FILTER	1	
11061	11061-2082	GASKET,MUFFLER	1	1
11061A	11061-2083	GASKET	1	1
11065	11065-2102	CAP	1	
	(-		
)	TH023-167459)		
11065A	11065-2114	CAP		1
11065B	11065-2114	CAP	1	
	(TH023-167460 -		
)			
14091	14091-2088	COVER	1	1
18020	18020-2082	BAFFLE	1	1
49069	49069-2369	MUFFLER-ASSY	1	1
59156	59156-2285	PIPE-TAIL	1	1
92009	92009-1002	SCREW,5X10	*	
92009A	92009-1182	SCREW	*	
92009B	92009-2393	SCREW,5X12	1	1
92009C	92009-2446	SCREW	4	4
92151	92151-2074	BOLT,5X55	2	2
92172	92172-0008	SCREW	1	
	(-		
)	TH023-167459)		
92172A	92172-2081	SCREW,5X20		1
92172B	92172-2081	SCREW,5X20	1	
	(TH023-167460 -		
)			

This catalog covers:

TH023V- □ C50

This fig. covers:

07 FUEL-TANK/FUEL-VALVE

E0200-A598A

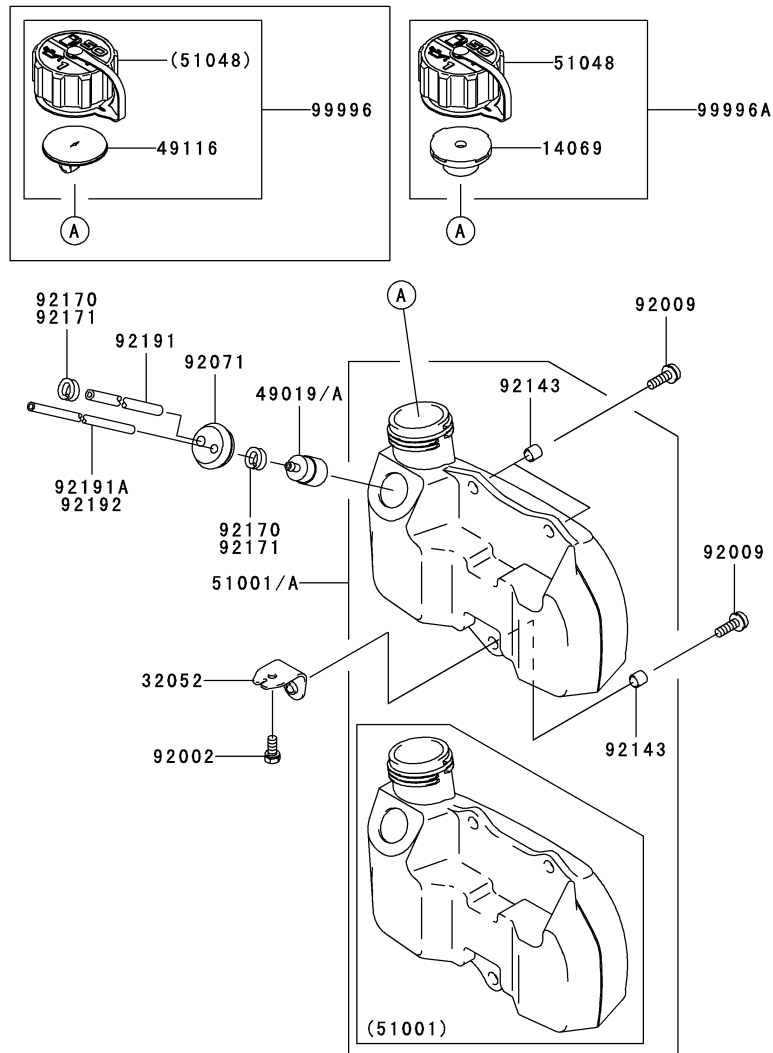

Ref. No.	Part No.	Description	Quantity	
			A	B
14069	14069-2088	BREATHER		1
32052	32052-2228	BRACKET-TANK	1	1
49019	49019-2111	FILTER-FUEL	1	
49019A	49019-2114	FILTER-FUEL		1
49116	49116-2064	VALVE-ASSY	1	
51001	51001-2310	TANK-COMP-FUEL	1	
51001A	51001-2329	TANK-COMP-FUEL		1
51048	51048-2078	CAP-ASSY-TANK	1	1
92002	92002-2313	BOLT	1	1
92009	92009-2368	SCREW,5X16	3	3
92071	92071-2142	GROMMET,FUEL TANK	1	1
92143	92143-2161	COLLAR,TANK	3	3
92170	92170-2080	CLAMP,FUEL FILTER	2	
92171	92171-2073	CLAMP		2
92191	92191-2154	TUBE	1	1
92191A	92191-2155	TUBE	1	
92192	92192-2148	TUBE,3X6X145		1
99996	99996-6060	KIT,CAP-ASSY-TANK	1	
99996A	99996-6088	CAP-TANK & BREATHER,ASSY		1

This catalog covers:

TH023V- □ C50

This fig. covers:

08 STARTER

E0210-A259E

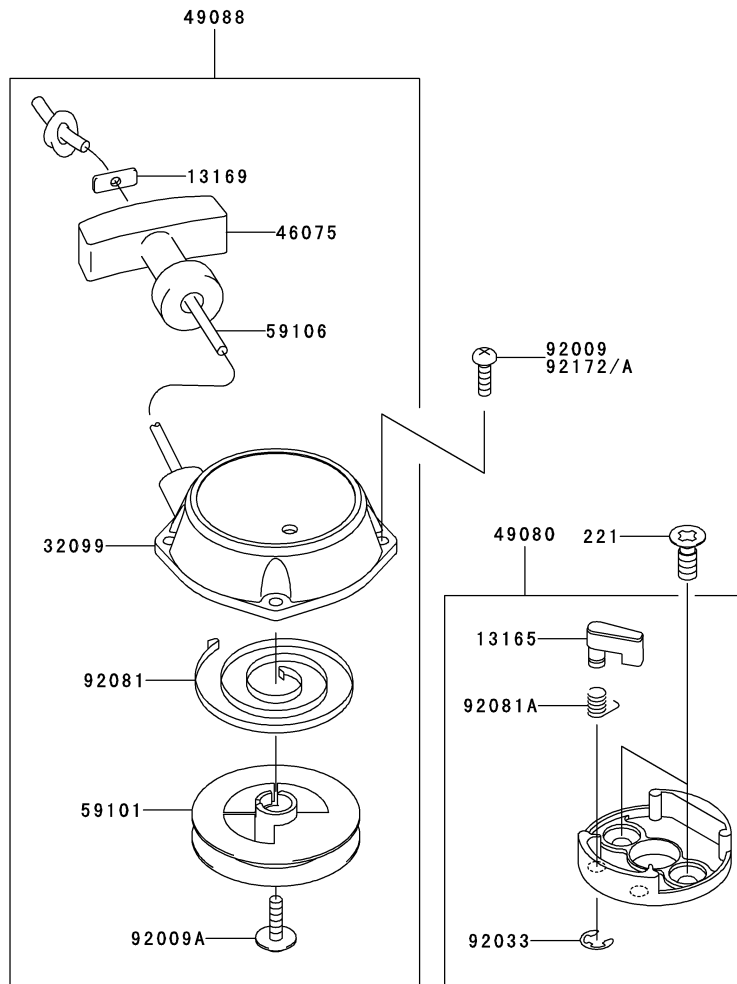

Ref. No.	Part No.	Description	Quantity	
			A	B
13165	13165-2052	PAWL	1	1
13169	13169-2386	PLATE,RECOIL STARTER	1	1
32099	32099-2406	CASE,STARTER-RECOIL		1
46075	46075-2116	GRIP,RECOIL STARTER	1	1
49080	49080-2099	PULLEY-STARTING	1	1
49088	49088-2515	STARTER-RECOIL	1	1
59101	59101-2106	REEL,RECOIL STARTER	1	1
59106	59106-2147	ROPE,3.5X800	1	1
92009	92009-2236	SCREW,4X14	*	
92009A	92009-2358	SCREW	1	1
92033	92033-2010	RING-SNAP	1	1
92081	92081-2238	SPRING,RECOIL	1	1
92081A	92081-2253	SPRING	1	1
92172	92172-2061	SCREW,4X14		4
92172A	92172-2061	SCREW,4X14	4	
221	221AA0616	SCREW-CSK-CROS,6X16	2	2

This catalog covers:

TH023V- □ C50

09

This fig. covers:

LABEL

F0290-A960A

Ref. No.	Part No.	Description	Quantity	
			A	B
56039	56039-2908	LABEL-PRODUCT	1	1
56070	56070-2020	LABEL-WARNING	1	1
56080	56080-2088	LABEL-BRAND	1	1

56039



56070



56080

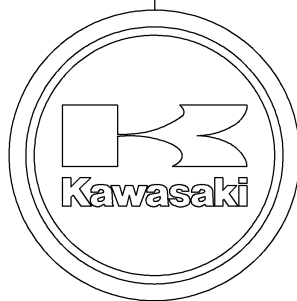

This catalog covers:

TH023V- □ C50

This fig. covers:

PART NAME INDEX

AIR-FILTER/MUFFLER.....	06
CARBURETOR.....	05
COOLING-EQUIPMENT.....	03
CYLINDER/CRANKCASE	01
ELECTRIC-EQUIPMENT.....	04
FUEL-TANK/FUEL-VALVE.....	07
LABEL.....	09
PISTON/CRANKSHAFT	02
STARTER.....	08

This catalog covers:

TH023V- C50

This fig. covers:

NUMERICAL PARTS INDEX

Part No.	Fig No.	Part No.	Fig No.	Part No.	Fig No.	Part No.	Fig No.	Part No.	Fig No.
11005-2150	01	49043-2067	05	92071-2160	03				
11010-2553	06	49069-2369	06	92081-2238	08				
11010-2572	06	49080-2099	08	92081-2253	08				
11010-2572	06	49088-2515	08	92143-2161	07				
11011-2332	06	49089-2552	03	92144-2308	05				
11013-2193	06	49089-2585	03	92151-2074	06				
11013-2208	06	49089-2585	03	92153-2069	04				
11013-2208	06	49116-2064	07	92170-2080	07				
11060-2111	05	49119-2205	02	92171-2073	07				
11060-2402	01	49119-2237	02	92172-0008	06				
11061-2054	05	51001-2310	07	92172-2061	03				
11061-2082	06	51001-2329	07	92172-2061	03				
11061-2083	06	51048-2078	07	92172-2061	08				
11061-2098	05	510A3100	04	92172-2061	08				
11061-2107	05	56039-2908	09	92172-2081	06				
11065-2102	06	56070-2020	09	92172-2081	06				
11065-2114	06	56080-2088	09	92191-2154	07				
11065-2114	06	59066-2763	03	92191-2155	07				
13001-2154	02	59066-2781	03	92192-2148	07				
13002-2058	02	59066-2781	03	92200-2063	03				
13008-6050	02	59101-2106	08	92200-2074	05				
13033-2055	02	59106-2147	08	92200-2156	03				
13165-2052	08	59156-2285	06	92200-2156	03				
13169-2386	08	92002-2163	01	92210-2089	05				
14002-2349	01	92002-2313	07	92210-2094	04				
14002-2350	01	92009-1002	06	99996-6060	07				
14043-2051	05	92009-1182	06	99996-6088	07				
14069-2088	07	92009-2115	01						
14090-2017	05	92009-2235	01						
14091-2088	06	92009-2236	03						
15003-2807	05	92009-2236	08						
16002-2058	05	92009-2249	05						
16030-2078	05	92009-2336	05						
16055-2051	05	92009-2337	05						
16073-2190	05	92009-2358	08						
16073-2197	03	92009-2368	07						
16073-2214	04	92009-2373	05						
16073-2215	04	92009-2393	06						
16073-2220	04	92009-2394	03						
16073-2231	05	92009-2395	03						
16073-2231	05	92009-2398	05						
16160-2089	05	92009-2446	06						
16160-2103	05	92015-2097	05						
18020-2082	06	92015-2145	05						
21050-2296	04	92025-2104	02						
21083-2073	05	92025-2105	02						
21130-2056	04	92025-2106	02						
21169-2051	04	92033-2010	08						
21169-2072	04	92033-2060	02						
21171-2241	04	92033-2078	05						
221AA0616	08	92033-2191	02						
26011-2372	04	92033-2191	02						
26011-2373	04	92043-1302	01						
32052-2228	07	92043-2094	05						
32099-2406	08	92045-2060	01						
43028-2067	05	92049-2108	01						
43028-2090	05	92055-2147	05						
46075-2116	08	92063-2425	05						
49019-2111	07	92070-2108	04						
49019-2114	07	92071-2142	07						