

TM2600

CUTTER, HANDLE

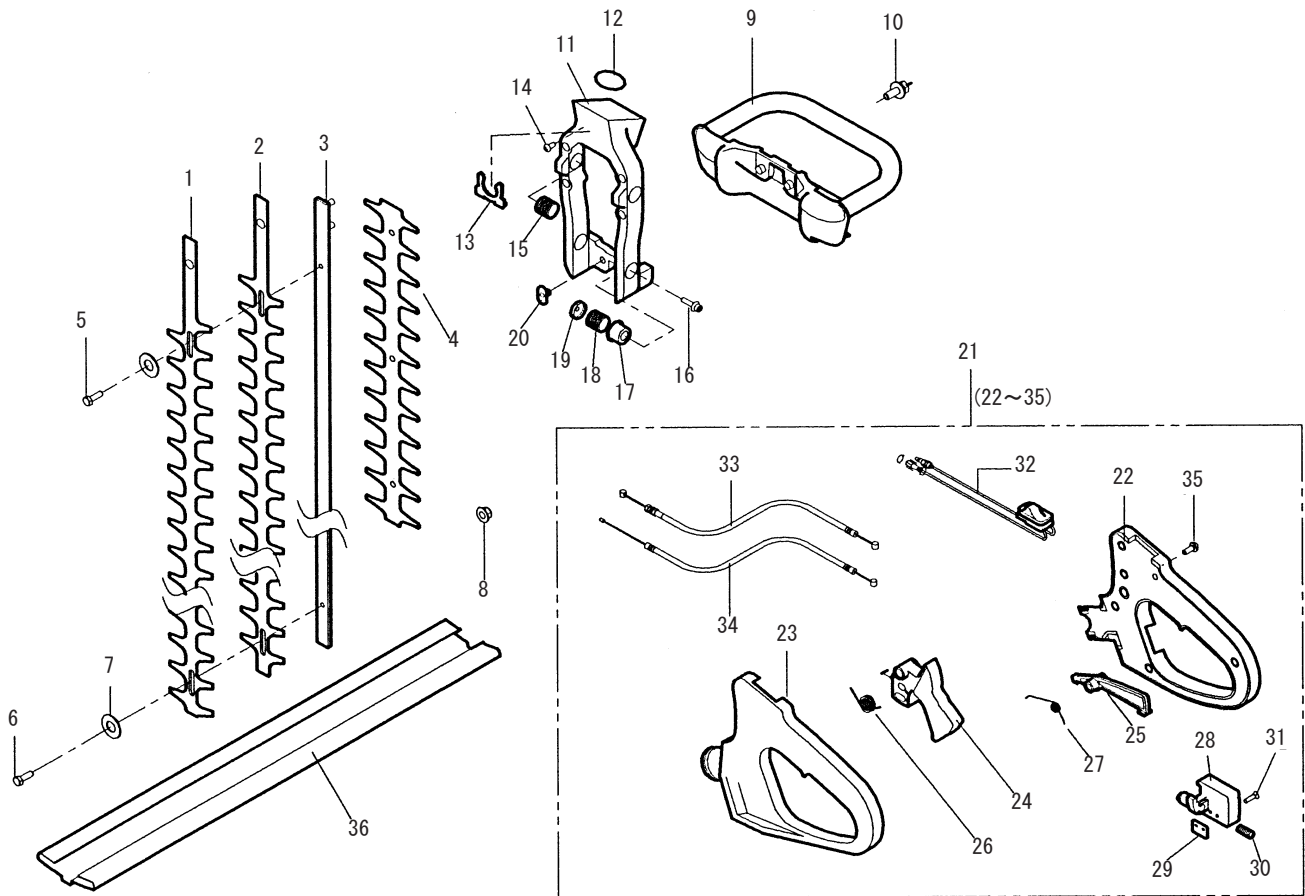

PARTS LIST

REF. No.	PARTS No.		PARTS NAME	CUTTER, HANDLE		3/4	Jun, 2003	REMARKS
				Q'TY	NCLUD NG			
1	91053	124	CUTTER(A)	1				
2	91054	115	CUTTER(B)	1				
3	11051	129	CUTTER GUIDE	1				
4	51090	122	PROTECTOR	1				
5	31029	105	STEP BOLT (L)	1				
6	31029	110	STEP BOLT (S)	3				
7	68002	101	CUTTER WASHER	4				
8	584L	0600	U-HEXAGON NUT FLANGE	4				M6
9	51027	238	HANDLE	1				
10	31057	235	BOLT	2				M5 × 20 (SW, PW)
11	51022	171	BRACKET	1				
12	214B	5000	O-RING	1				S50
13	11086	179	STOPPER	1				
14	477L	0408	(+) TRUSS TAPPING SCREW	2				
15	68013	326	SPRING	2				
16	423U	0515	SOCKET SCREW FLANGE	4				
17	11102	210	HOLDER	4				
18	68013	327	SPRING	2				
19	11102	209	HOLDER	4				
20	31038	102	FIXING NUT	2				
21	71014	368	HANDLE ASS'Y	1				
22	51106	127	HANDLE R		1			
23	51106	128	HANDLE R		1			
24	91010	190	THROTTLE LEVER		1			
25	36081	113	LOCK LEVER		1			