

TM3100

CUTTER , HANDLE

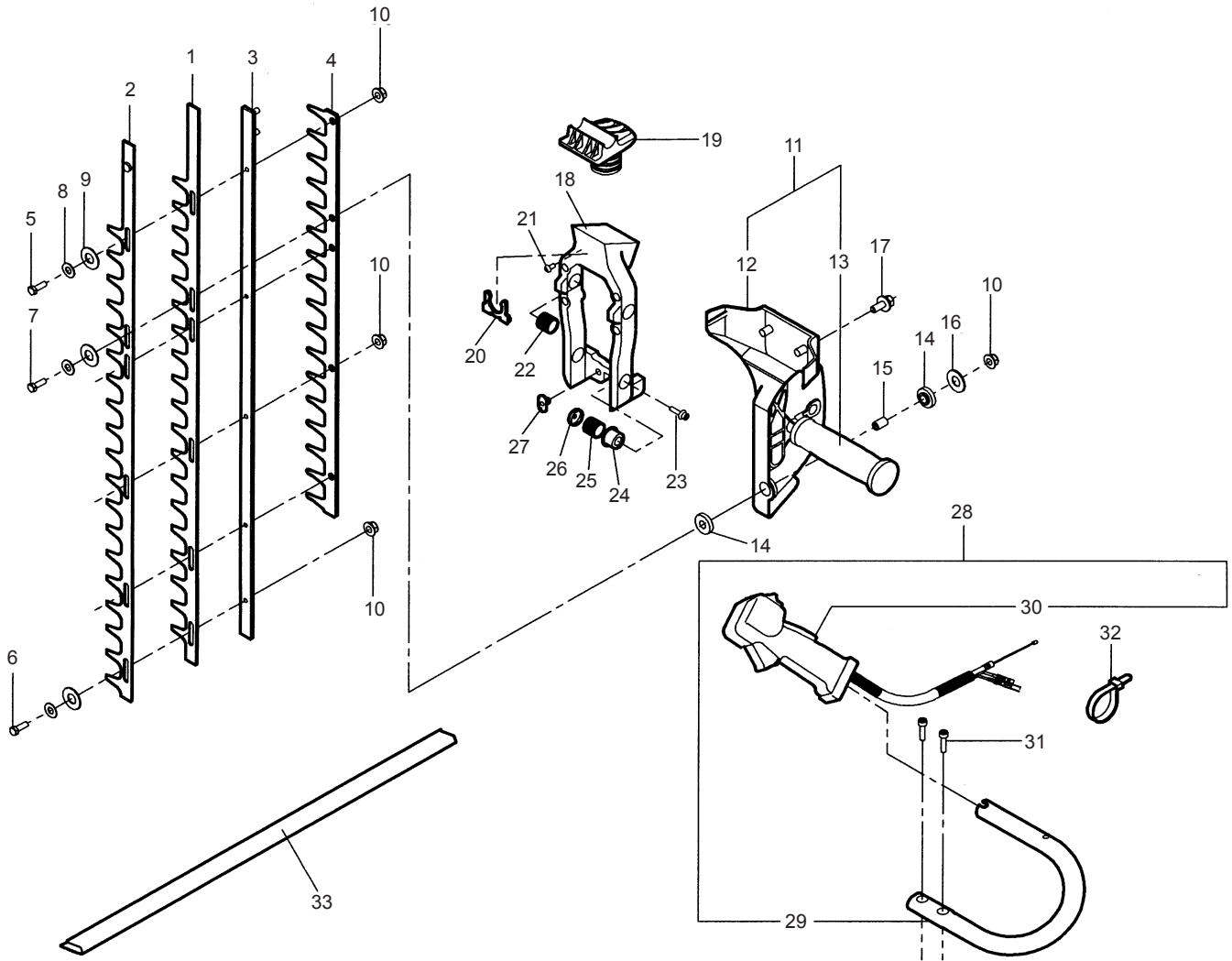

PARTS LIST

REF. No.	PARTS No.		PARTS NAME	Q'TY		REMARKS
					NCLUD NG	
1	91053	122	CUTTER(A)	1		
2	91054	113	CUTTER(B)	1		
3	11051	128	CUTTER GUIDE	1		
4	51090	129	PROTECTOR	1		
5	31029	112	STEP BOLT(S)	1		
6	31029	105	STEP BOLT(S)	4		
7	31030	105	STEP BOLT(L)	1		
8	670V	0700	CONICAL SPRING WASHER	6		M6
9	68002	101	CUTTER WASHER	6		
10	584L	0600	U-HEXAGON NUT FLANGE	6		M6
11	71014	378	HANDLE ASS'Y	1		
12	51027	240	HANDLE	1		
13	36007	136	HANDLE GRIP	1		
14	36005	169	VIBRO-ISOLATING RUBBER	2		
15	11083	376	COLLAR	1		
16	68036	163	WASHER	1		
17	31057	235	BOLT	2		M5 × 20
18	51022	171	BRACKET	1		
19	51022	180	BRACKET	1		
20	11086	179	STOPPER	1		
21	477L	0408	(+)TRUSS TAPPING SCREW	2		M4 × 8
22	68013	326	SPRING	2		
23	423U	0515	SOCET SCREW FLANGE	4		M5 × 15
24	11102	210	HOLDER	4		
25	68013	327	SPRING	2		