

This catalog covers:
TH023V-□C54

This fig. covers:
TITLE

PARTS CATALOG

2-STROKE ENGINE

TH023V

PRODUCT CODE	NOTE
TH023V-AC54	HEDGE-TRIMMER (TM3200S)

PARTS CATALOG INTRODUCTION

This parts catalog lists parts and sub-assemblies provided as service parts.

When it becomes necessary to replace parts, always use KAWASAKI GENUINE PARTS which have passed strict inspection which guarantees quality and performance.

1. HOW TO ORDER PARTS

- When ordering the parts, be sure to use the parts catalog corresponding to the product code. Check the product revision codes on the product and the catalog.
 Product Code (example) : FA130D-AA00
└── Product Revision Code
- Specify the part code (all digits) exactly as listed in this catalog on your parts order.
- The parts not shown in the illustrations of this catalog are not sold separately; only the complete units or next higher assemblies illustrated are supplied as the service parts.

2. EXPLANATION OF PARTS CATALOG FORMAT

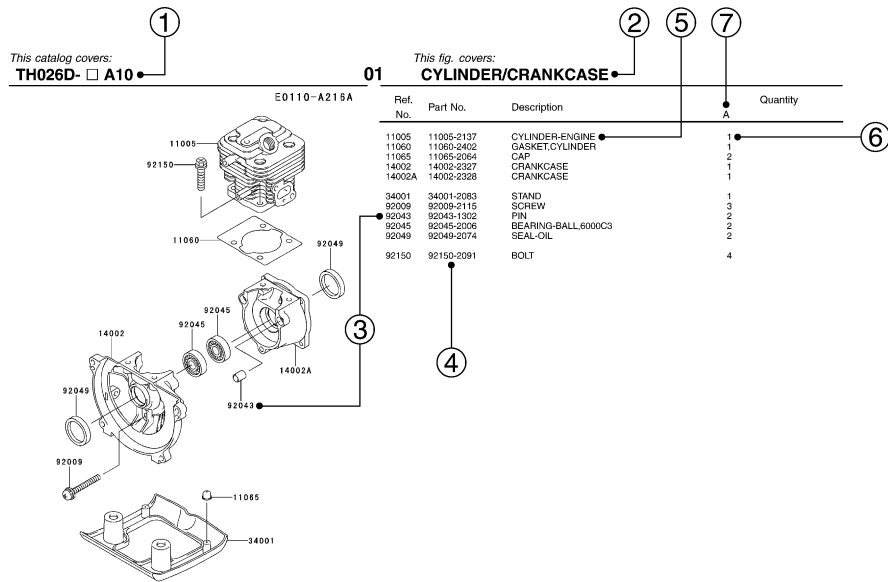

1) Product Code

This code describes the product code covered by this catalog. The product revision code, which is a part of the product code, is omitted.

2) Part Group Title

This title is the representative name for the group of parts illustrated on the page.

3) Reference Number

The reference numbers are shown on the illustration and the list as the link between them.

4) Part Number

This is the key of your parts ordering.

Three kinds of part number are used in this catalog.

- Structure 1
- Structure 2
- Standard Hardware Number
 (for bolts, nuts, washer, or the like)

5) Description and Additional Information

The part name, the location, the size, and the serial number as additional information, etc. are described here. Use them to find out and check the part required.

When a part number is changed without change of the product revision code and the changed parts are not interchangeable, the serial number of the product is noted as follows;

- (FA130 - 100001) : Affected units are from beginning of the product of the product code up to and including this serial number.
- (FA130 - 100002 -) : Affected units are from this serial number and above.
- (FA130 - 100002 - FA130 - 110001) : Affected units are in this serial number range.

6) Quantity

The figure shows quantity of the part required at the indicated position on the illustration and for the specified product revision code.

The asterisk (*) on this column means the part can be used as the substitute on the product and is supplied until the stock is exhausted.

Note:Some small parts will be supplied by units.

Example: If six (6) bolts are ordered and the minimum quantity per unit is five (5), two (2), units of the bolt will be delivered.

7) Product Revision Code

This Code indicates an important change which affects the service parts interchangeability.

3. ABBREVIATIONS

#.....Number	FR.....Front	RH.....Right Hand
&.....And	G.....Gram	RPM.....Revolutions Per Minute
(+).....Plus	HEX.....Hexagonal	RR.....Rear
(-).....Minus	ID=.....Inside Diameter	STD.....Standard
2ND.....Second	IN.....Inch	T.....Teeth
3RD.....Third	L=.....Length	T=.....Thickness
4TH.....Fourth	LH.....Left Hand	U/S.....Under Size
A.....Ampere	LWR.....Lower	UPP.....Upper
AR.....As Required	MM.....Millimeter	V.....Volt
ASSY.....Assembly	O/S.....Over Size	W.....Watt
CNT.....Center	OD=.....Outside Diameter	
COMP.....Complete	REF.....Reference	

This catalog covers:

TH023V- □ C54

This fig. covers:

01 CYLINDER/CRANKCASE

E0110-A391A

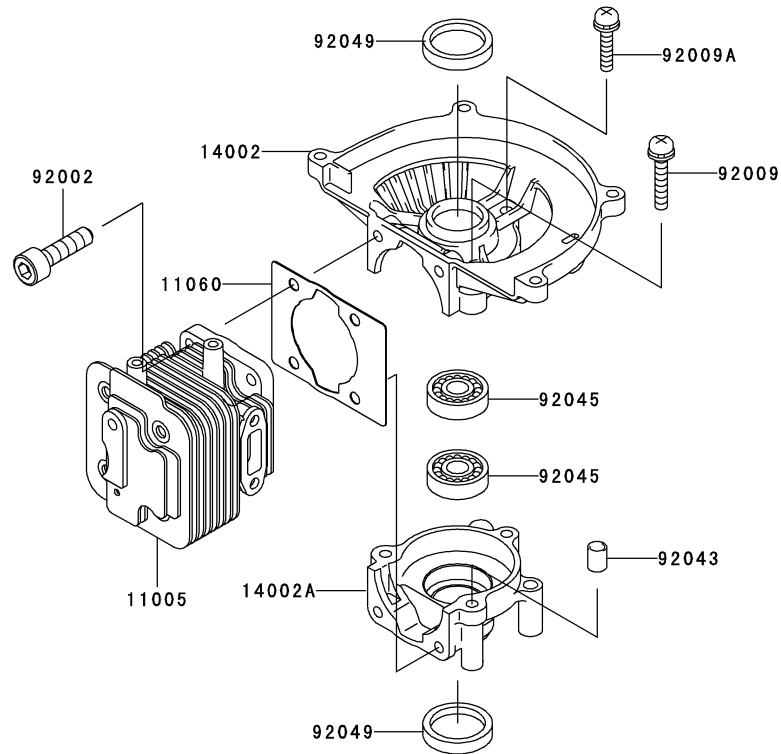

Ref. No.	Part No.	Description	Quantity
11005	11005-2150	CYLINDER-ENGINE	1
11060	11060-2402	GASKET,CYLINDER	1
14002	14002-2349	CRANKCASE	1
14002A	14002-2350	CRANKCASE	1
92002	92002-2163	BOLT	4
92009	92009-2115	SCREW	2
92009A	92009-2235	SCREW,5X25	1
92043	92043-1302	PIN	2
92045	92045-2060	BEARING-BALL,6001V3	2
92049	92049-2108	SEAL-OIL	2

This catalog covers:

TH023V- □ C54

02

This fig. covers:

PISTON/CRANKSHAFT

E0120-A204A

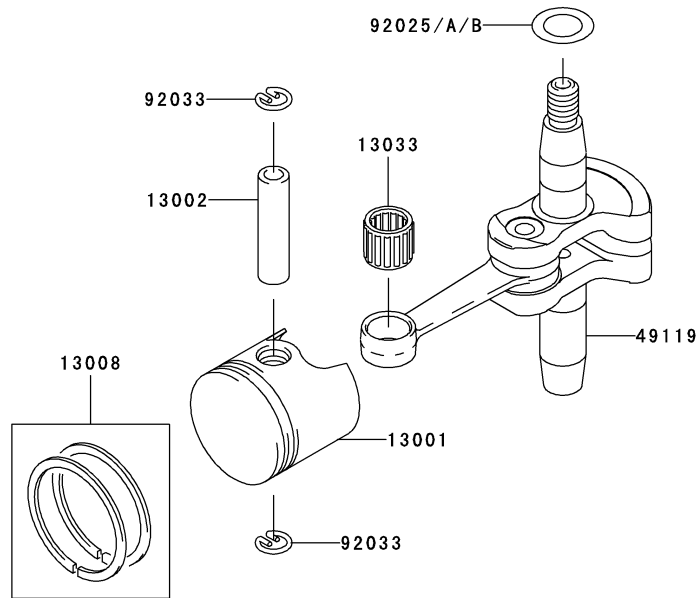

Ref. No.	Part No.	Description	Quantity
13001	13001-2154	PISTON-ENGINE	1
13002	13002-2058	PIN-PISTON	1
13008	13008-6050	RING-SET-PISTON	1
13033	13033-2055	BEARING-SMALL END	1
49119	49119-2237	CRANKSHAFT-ASSY	1
92025	92025-2104	SHIM,T=0.20	AR
92025A	92025-2105	SHIM,T=0.40	AR
92025B	92025-2106	SHIM,T=0.60	AR
92033	92033-2191	RING-SNAP	2

This catalog covers:

TH023V- □ C54

03

This fig. covers:

COOLING-EQUIPMENT

E0150-A459C

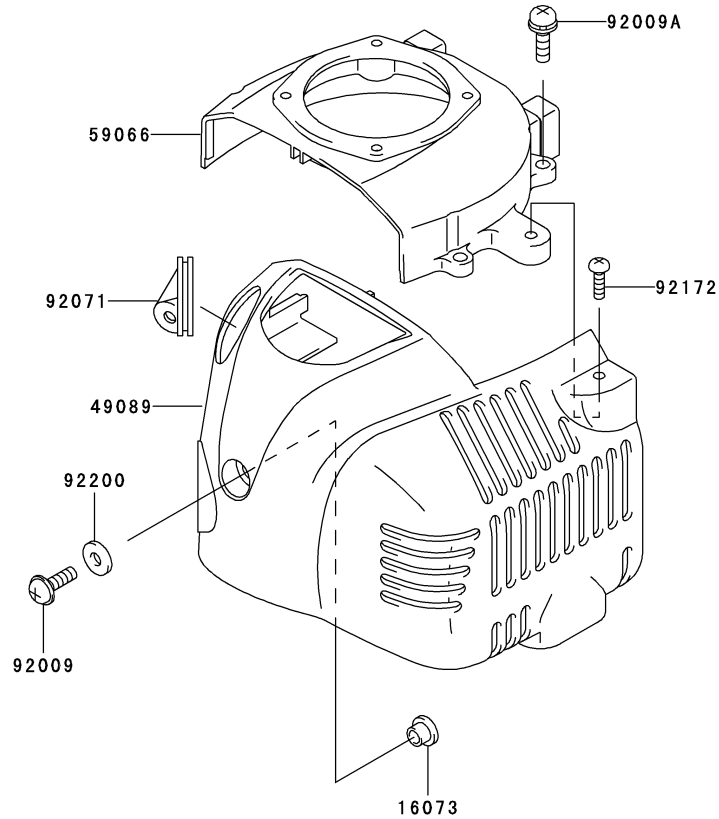

Ref. No.	Part No.	Description	Quantity
16073	16073-2197	INSULATOR	1
49089	49089-2684	SHROUD-ENGINE	1
59066	59066-2815	HOUSING-FAN	1
92009	92009-2394	SCREW,5X16	1
92009A	92009-2395	SCREW,5X16	4
92071	92071-2160	GROMMET	1
92172	92172-2061	SCREW,4X14	1
92200	92200-2156	WASHER	1

This catalog covers:

TH023V- □ C54

This fig. covers:

04 ELECTRIC-EQUIPMENT

E0160-B195A

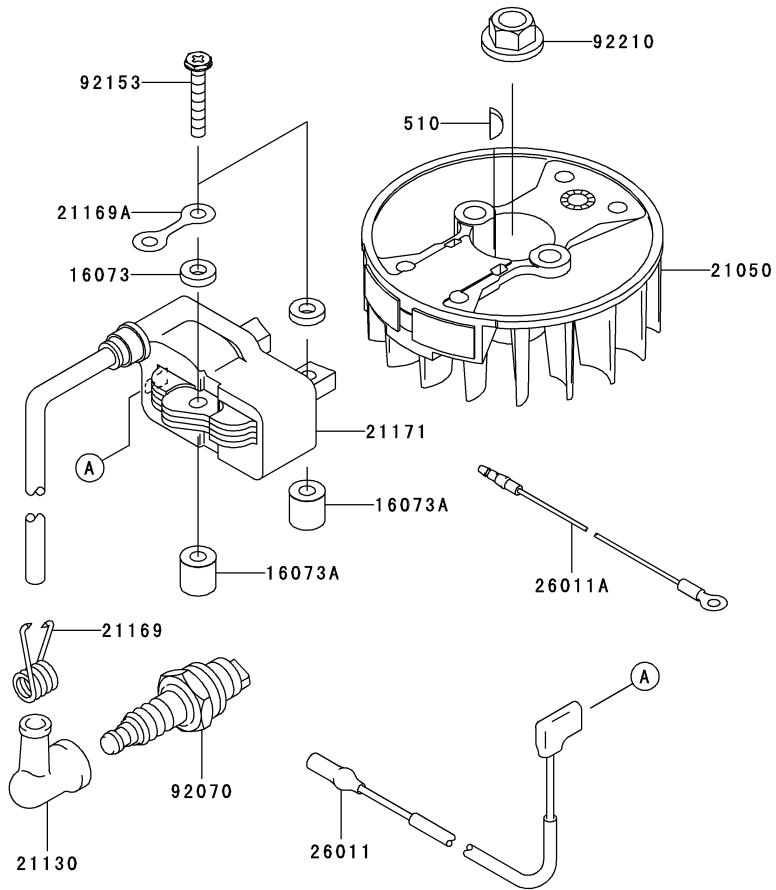

Ref. No.	Part No.	Description	Quantity
16073	16073-2215	INSULATOR	2
16073A	16073-2220	INSULATOR	2
21050	21050-2296	FLYWHEEL	1
21130	21130-2056	CAP-SPARK PLUG	1
21169	21169-2051	TERMINAL	1
21169A	21169-2072	TERMINAL	1
21171	21171-2241	COIL-ASSY-IGNITION	1
26011	26011-2372	WIRE-LEAD,X260	1
26011A	26011-2373	WIRE-LEAD,X130	1
92070	92070-2108	PLUG-SPARK,BPMR6A(NGK),SOLID	1
92153	92153-2069	BOLT,04X25	2
92210	92210-2094	NUT	1
510	510A3100	KEY-WOODRUFF	1

This catalog covers:

TH023V- □ C54

This fig. covers:

05 CARBURETOR

E0180-A629A

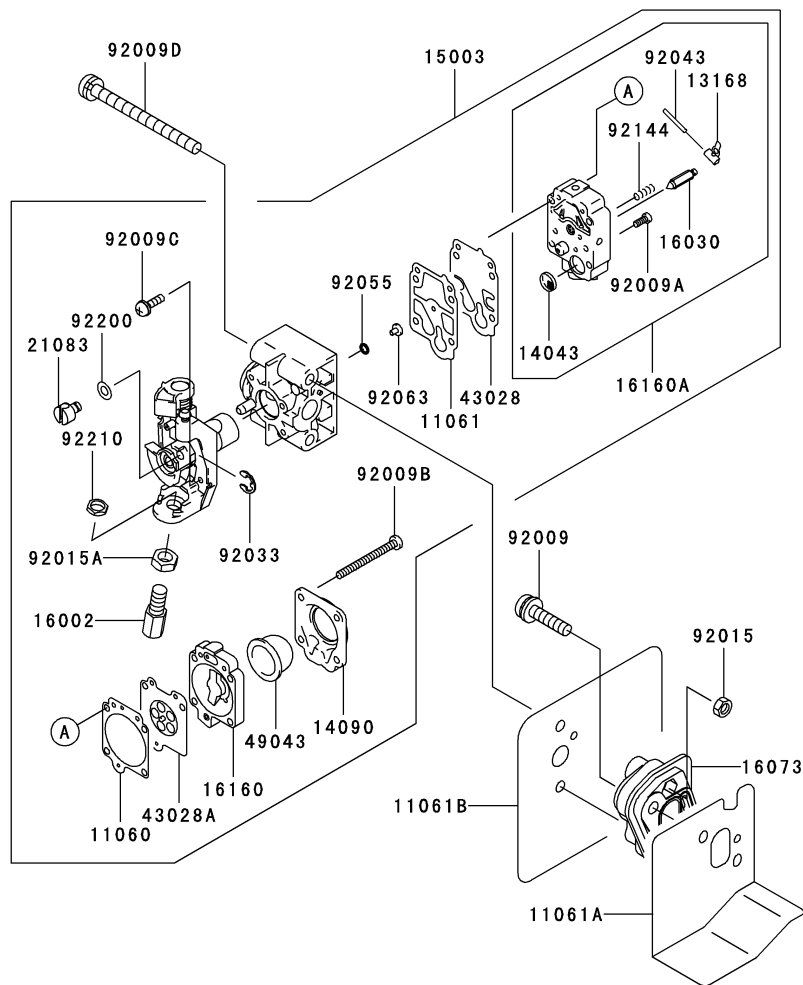

Ref. No.	Part No.	Description	Quantity
11060	11060-2111	GASKET	1
11061	11061-2054	GASKET	1
11061A	11061-2098	GASKET	1
11061B	11061-2107	GASKET,CARBURETOR	1
13168	16055-2051	LEVER	1
14043	14043-2051	FILTER	1
14090	14090-2017	COVER,PRIMER PUMP	1
15003	15003-2807	CARBURETOR-ASSY	1
16002	16002-2058	ADJUSTER-CABLE	1
16030	16030-2078	VALVE-FLOAT	1
16073	16073-2231	INSULATOR	1
16160	16160-2089	BODY	1
16160A	16160-2103	BODY	1
21083	21083-2073	ARM	1
43028	43028-2067	DIAPHRAGM	1
43028A	43028-2090	DIAPHRAGM	1
49043	49043-2067	PUMP-PRIMING	1
92009	92009-2249	SCREW,5X20	2
92009A	92009-2336	SCREW	1
92009B	92009-2337	SCREW	4
92009C	92009-2373	SCREW	2
92009D	92009-2398	SCREW,5X60	2
92015	92015-2097	NUT,M5	2
92015A	92015-2145	NUT	1
92033	92033-2078	RING-SNAP	1
92043	92043-2094	PIN	1
92055	92055-2147	RING-O	1
92063	92063-2425	JET-MAIN,#32.5	1
92144	92144-2308	SPRING	1
92200	92200-2074	WASHER	1
92210	92210-2089	NUT	1

This catalog covers:

TH023V- □ C54

This fig. covers:

06 AIR-FILTER/MUFFLER

E0190-A731A

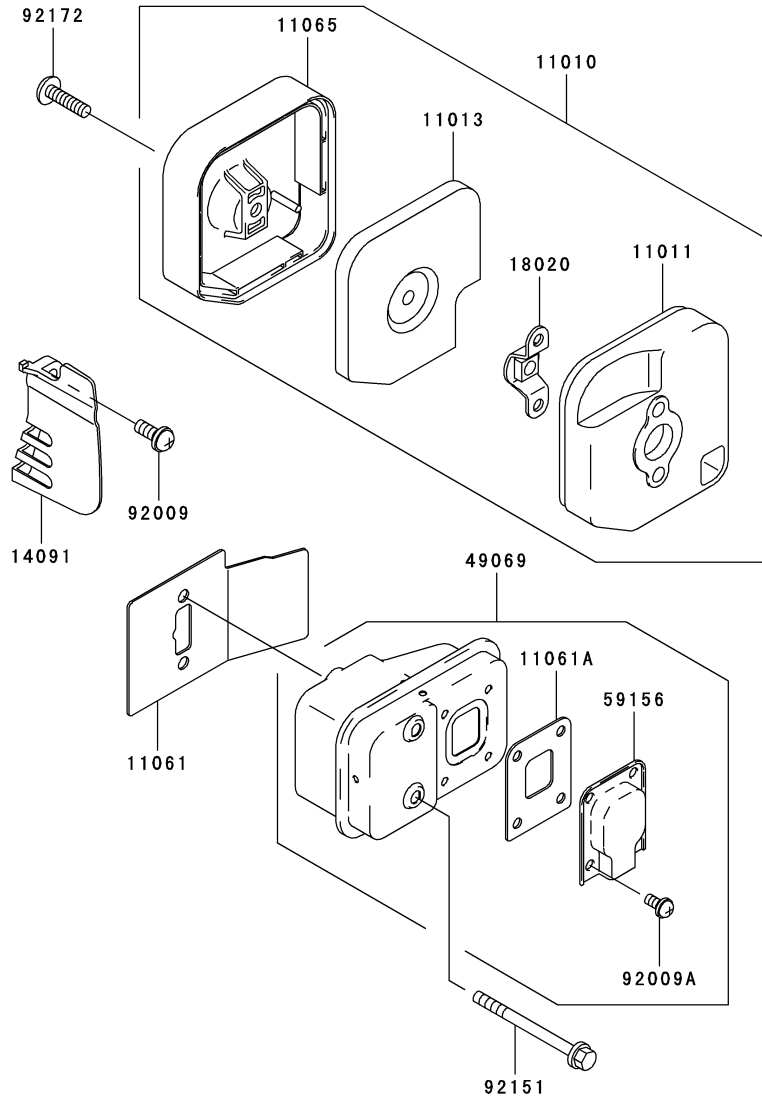

Ref. No.	Part No.	Description	Quantity
11010	11010-2572	FILTER-ASSY-AIR	1
11011	11011-2332	CASE-AIR FILTER	1
11013	11013-2208	ELEMENT-AIR FILTER	1
11061	11061-2082	GASKET,MUFFLER	1
11061A	11061-2083	GASKET	1
11065	11065-2114	CAP	1
14091	14091-2088	COVER	1
18020	18020-2082	BAFFLE	1
49069	49069-2369	MUFFLER-ASSY	1
59156	59156-2285	PIPE-TAIL	1
92009	92009-2393	SCREW,5X12	1
92009A	92009-2446	SCREW	4
92151	92151-2074	BOLT,5X55	2
92172	92172-2081	SCREW,5X20	1

This catalog covers:

TH023V- □ C54

This fig. covers:

07 FUEL-TANK/FUEL-VALVE

E0200-A638A

Ref. No.	Part No.	Description	Quantity
14069	14069-2088	BREATHER	1
32052	32052-2228	BRACKET-TANK	1
49019	49019-2114	FILTER-FUEL	1
51001	51001-2329	TANK-COMP-FUEL	1
51048	51048-2078	CAP-ASSY-TANK	1
92002	92002-2313	BOLT	1
92009	92009-2368	SCREW,5X16	3
92071	92071-2142	GROMMET,FUEL TANK	1
92143	92143-2161	COLLAR,TANK	3
92171	92171-2073	CLAMP	2
92191	92191-2154	TUBE	1
92192	92192-2148	TUBE,3X6X145	1
99996	99996-6088	CAP-TANK & BREATHER,ASSY	1

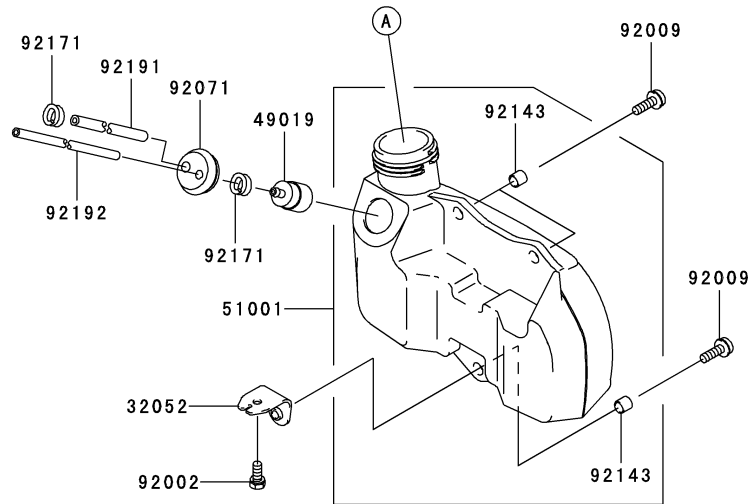
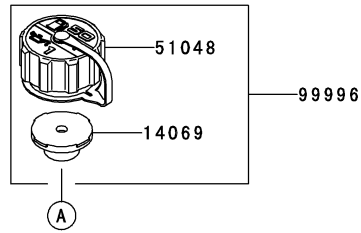

This catalog covers:

TH023V- □ C54

This fig. covers:

08 STARTER

E0210-A259G

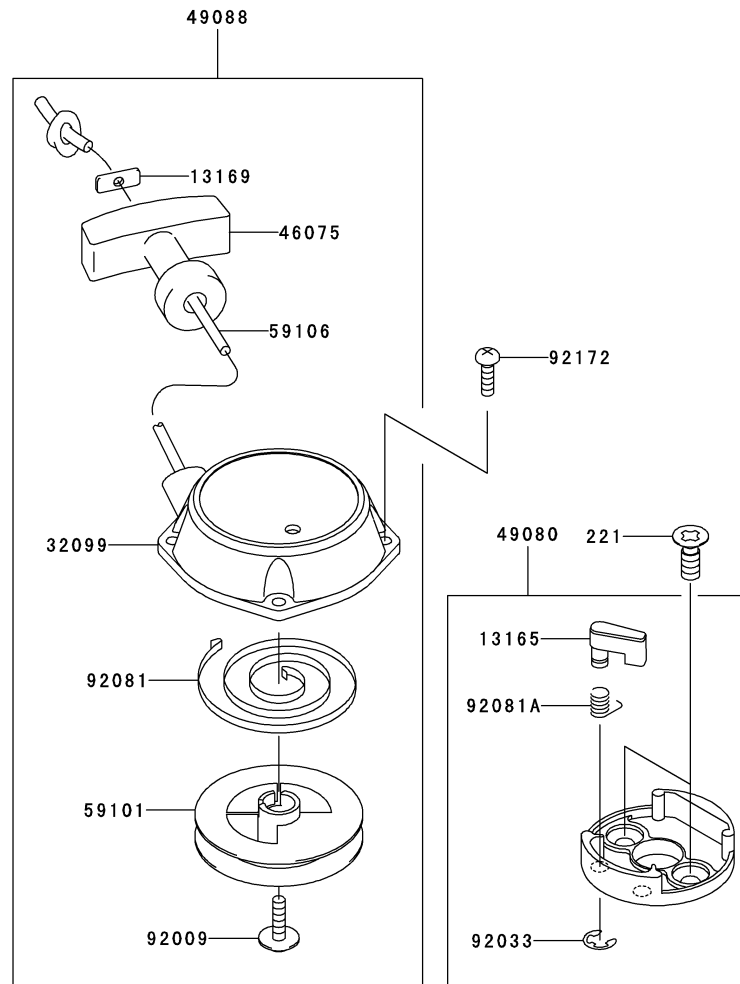

Ref. No.	Part No.	Description	Quantity
13165	13165-2052	PAWL	1
13169	13169-2386	PLATE,RECOIL STARTER	1
32099	32099-2406	CASE,STARTER-RECOIL	1
46075	46075-2116	GRIP,RECOIL STARTER	1
49080	49080-2099	PULLEY-STARTING	1
49088	49088-2515	STARTER-RECOIL	1
59101	59101-2106	REEL,RECOIL STARTER	1
59106	59106-2147	ROPE,3.5X800	1
92009	92009-2358	SCREW	1
92033	92033-2010	RING-SNAP	1
92081	92081-2238	SPRING,RECOIL	1
92081A	92081-2253	SPRING	1
92172	92172-2061	SCREW,4X14	4
221	221AA0616	SCREW-CSK-CROS,6X16	2

This catalog covers:

TH023V- □ C54

09

This fig. covers:

LABEL

F0290-B431A

Ref. No.	Part No.	Description	Quantity
56039	56039-2971	LABEL-PRODUCT	1
56070	56070-2020	LABEL-WARNING	1
56080	56080-2088	LABEL-BRAND	1

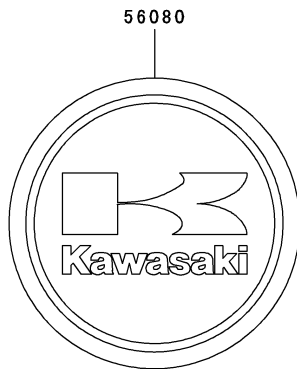
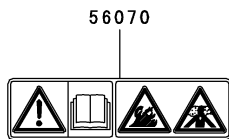
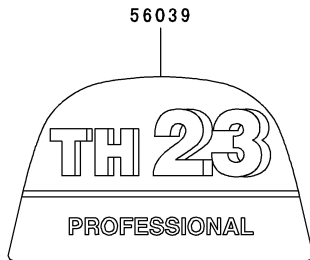

This catalog covers:

TH023V- □ C54

This fig. covers:

PART NAME INDEX

AIR-FILTER/MUFFLER.....	06
CARBURETOR.....	05
COOLING-EQUIPMENT.....	03
CYLINDER/CRANKCASE	01
ELECTRIC-EQUIPMENT.....	04
FUEL-TANK/FUEL-VALVE.....	07
LABEL.....	09
PISTON/CRANKSHAFT	02
STARTER.....	08

P i Pa Li [FRMPARTSLIST]

M
 Se ec b a d P d c
 Se ec de c de M de a e Search
 I dica e e a ..Ch e ec i < > Reset
 I dica e e gi e de ..Ch e ec i < > Reset

E e i f a i i he g e e b a d he ea cha d he c i c he "Sea ch" b .

GEAR CASE

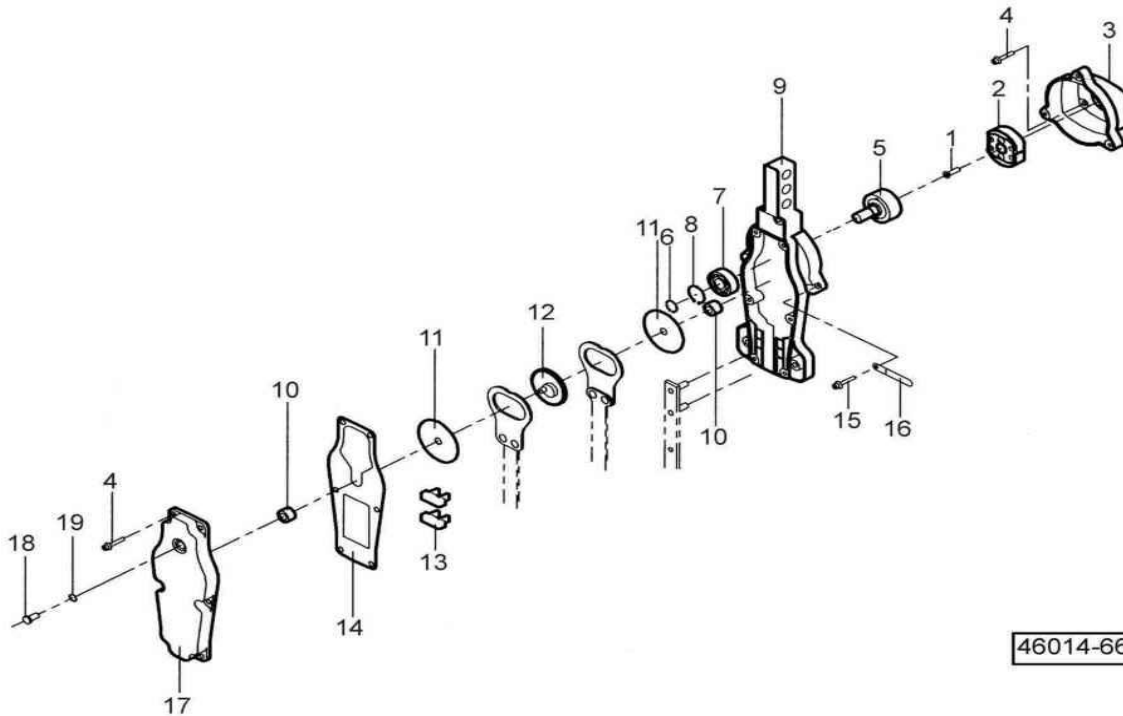

46014-666-01

- (A) TME2200
- (B)
- (C)

Ref.N	Pa .N	Pa .Na e	(A)Q'	(B)Q'	(C)Q'	Re a
1	461L0620	(+)FLAT SCREW	1			
2	71019-114	CLUTCH SHOE ASS Y	1			
3	51070-130	ENGINE BASE	1			
4	423U0515	SOCKET SCREW FLANGE	10			
5	11014-221	CLUTCH DRUM C.P.	1			
6	812V1500	C-SNAP RING	1			
7	917B6202	BEARING (6202ZZC3)	1			
8	811V3500	C-SNAP RING	1			
9	51068-109	CAM CASE	1			
10	76007-182	BUSH	2			
11	11050-176	FIXING PLATE	2			
12	78004-304	GEAR	1			
13	61010-113	FELT PACKING	2			
14	61019-224	PACKING	1			
15	423U0518	SOCKET SCREW FLANGE	3			
16	68027-109	CLIP	1			
17	51069-105	CAM CASE COVER	1			
18	429U0808	SOCKET SCREW	1			
19	214B0700	O-RING (S7)	1			

P i Pa Li [FRMPARTSLIST]

P M

Se e b a d

M d e a e

Se e d e c d e

..Ch e e c i

I d i c a e e a

..Ch e e c i

I d i c a e e g i e d e

..Ch e e c i

E e i f a i i h e g e e b a d h e e a c h a d h e c i c h e "Sea ch" b

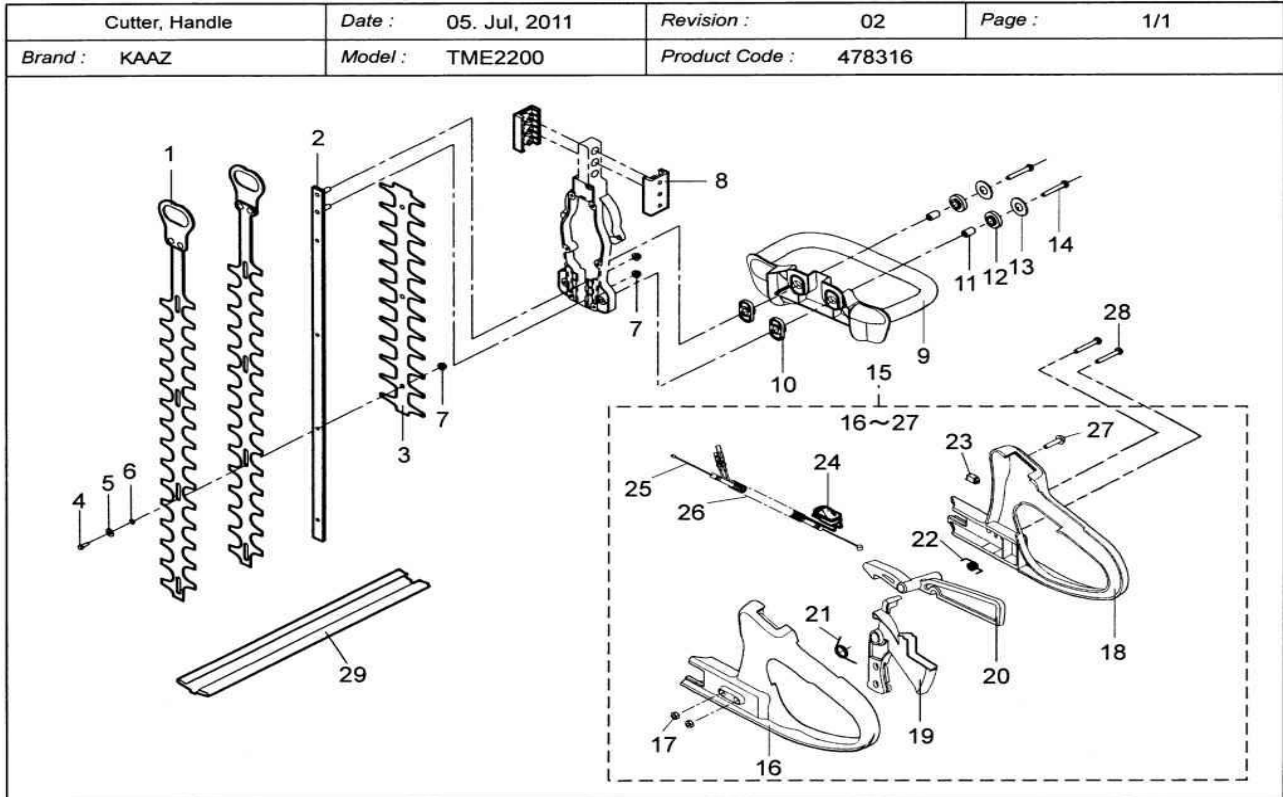

- (A) TME2200
- (B)
- (C)

Ref.N	Pa .N	Pa .Na e	(A)Q`	(B)Q`	(C)Q`	Re a
1	91054-122	CUTTER(B)	2			
2	11051-132	CUTTER GUIDE	1			
3	51090-135	PROTECTOR	1			
4	31029-110	STEP BOLT(S)	4			
5	670V0700	SPRING WASHER	4			
6	68002-101	CUTTER WASHER	4			
7	584L0600	U-FLANGE NUT	6			
8	36006-128	ABSORBER	2			
9	51027-279	HANDLE	1			
10	36005-176	RUBBER	2			
11	11083-381	COLLAR	2			
12	36005-169	RUBBER	2			
13	68036-268	WASHER (5.5 25 1.2)	2			
14	413U0530	SOCKET SCREW(W/SW)	2			
15	71014-493	HANDLE ASS Y	1			
16	51106-143	HANDLE(R)	1			
17	562L0500	U-HEXAGON NUT	2			
18	51106-144	HANDLE(R)	1			
19	11095-182	LEVER	1			
20	11095-181	LEVER	1			
21	68013-321	SPRING	1			
22	68013-367	SPRING	1			
23	91033-135	BLIND COVER	1			
24	71148-176	STOP SWITCH ASS Y	1			
25	91001-323	THROTTLE WIRE	1			
26	41003-218	TUBE	1			
27	474L0420	(+)TAPPING SCREW	4			
28	412L0540	SOCKET SCREW	2			
29	36065-475	COVER	1			